

Oil Pressure Functional Module (FM-OP) Installation Instructions and Wiring Diagram

1110983

II 1119981 Supplement

11/10/98

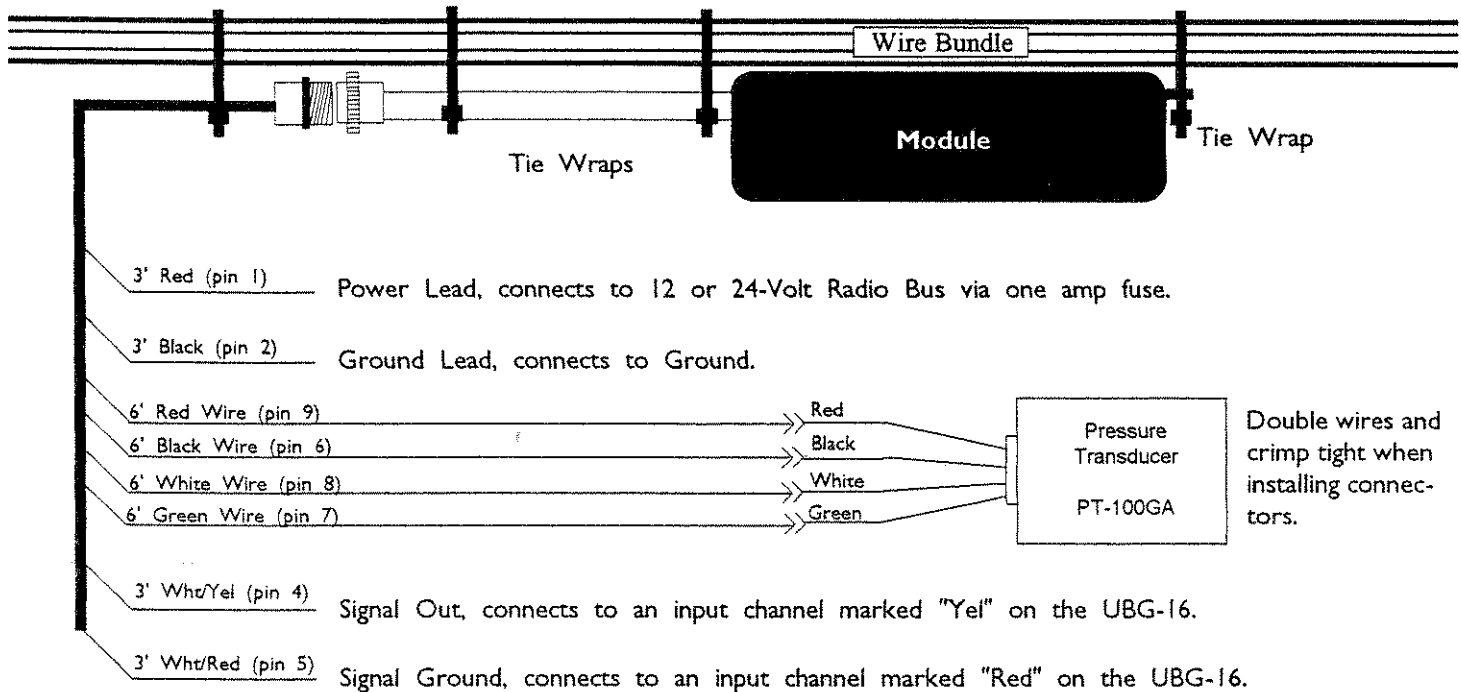

1. Mount the Module and Connect the 9-Pin Wire Harness:

Tie wrap the FM-OP Module to a wire bundle under the aircraft instrument panel. Connect the 9-Pin Wire Harness to the Module.

2. Route the Power and Ground Wires:

Route the red wire in the wire harness to the aircraft's 12 or 24-volt radio or main bus as applicable via a one amps fuse. Route the black wire in the wire harness to a good ground. **Tie wrap these wires so they do not obstruct the freedom of travel of any controls.**

3. Install the Oil Pressure Transducer:

Find a convenient location on the fire wall and mount the oil pressure transducer with the clamp provided. **Do not mount the pressure transducer to an engine baffle or directly on the engine supported by an adapter or fitting.** Vibration can cause the adapter to break. The oil pressure transducer is equipped with a 1/8" NPT male port. This port can be adapted to any oil pressure line. Use only a flexible hose and fittings suitable for aircraft use. Route a flexible oil pressure line from the oil pressure pick up point to the oil pressure transducer and tighten all fittings. **Do not use the case of the pressure transducer to tighten the pressure fittings.**

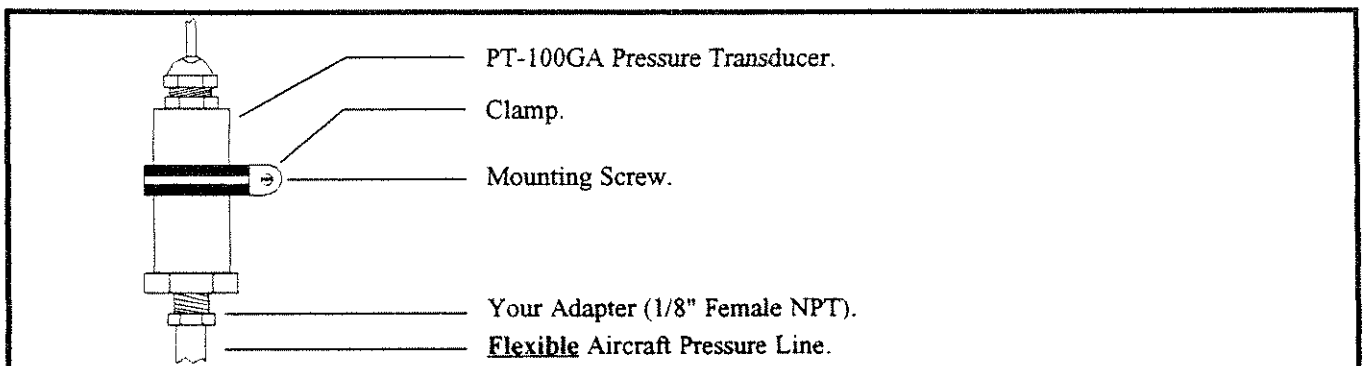

4. Route the Pressure Transducer Extension Wires:

Route the four 6 foot pressure transducer wires (red, black, green and white) in the wire harness to the oil pressure transducer and cut to length. These wires may be spliced if extra wire length is required. Install the male connectors (supplied with the kit) on the four wires and connect them to the pressure transducer matching the colors of the wires. Be sure the wires are doubled over and double crimped onto the connectors. **Tie wrap these wires so they do not obstruct the freedom of travel of any controls.**

5. Route the Signal Out and Ground Wires to the UBG-16:

Route the White/Yellow wire to the appropriate left or right channel on the UBG-16 marked "Yel." Route and connect the White/Red wire to the appropriate channel on the UBG-16 marked "Red." **Tie wrap all wires so they do not obstruct the freedom of travel of any controls.**

UBG Extension Cable Harness (Left or Right)
Back View (wire side)

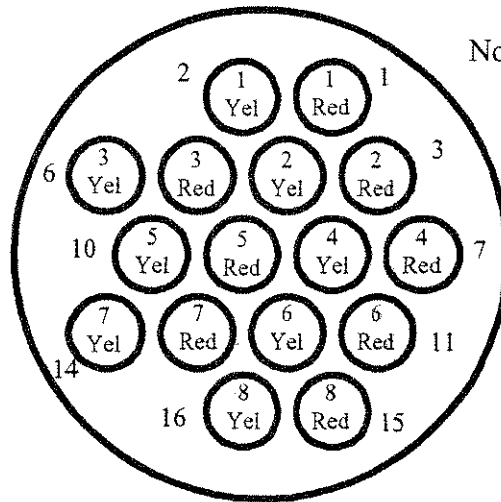

Note: 1 Red = Channel #1 Red wire (Gnd)
1 Yel = Channel #1 Yel wire (Signal)

Specifications and Operating Features

Model:

FM-OP (Oil Pressure Functional Module)

Case Dimensions:

3" x 2" x 1"

Weight:

Module Only: 2.8 Oz.

Environmental:

Meets TSO C47.

Power Requirements:

7.5 to 35 Volts, 1/10 Amp.

Accuracy:

2% or better in accordance with TSO C47.

Resolution:

1 PSI

Pressure Transducer Specifications (PT-100GA):

Range: 0 to 100 psi.
Over Press: 300 psi. without damage.
Min. Burst Press: 500 psi.
Temp. Range: -40°C to 125°C
Material: 316L Stainless Steel
Press. Port: 1/8" NPT Male