

R-1-N2
Operation/Installation Manual Supplement
M0907012

9/07/01

1. **Resolution** - The R-1-N2 displays in 10 RPM increments.
2. **Fight Timer** - The Flight Timer resets and starts timing when the RPM exceeds 1500 for 10 seconds. The Flight Timer stops when the RPM drops below 1200 for 10 seconds.
3. **Tach Timer** - The Tach Timer runs for RPM's above 1300.
4. **Hookup** – Connect the Orange lead from the unit to either terminal on the N2 Tach Generator. Do not use isolators in this lead.
5. Reading below 300 RPM display as 0000 RPM.
6. Unless specified otherwise, 4200p/m from Tach Generator equals 1670 RPM reading on the R-1-N2 Instrument.

R-1-N2

Wiring Diagram

WD 0907011

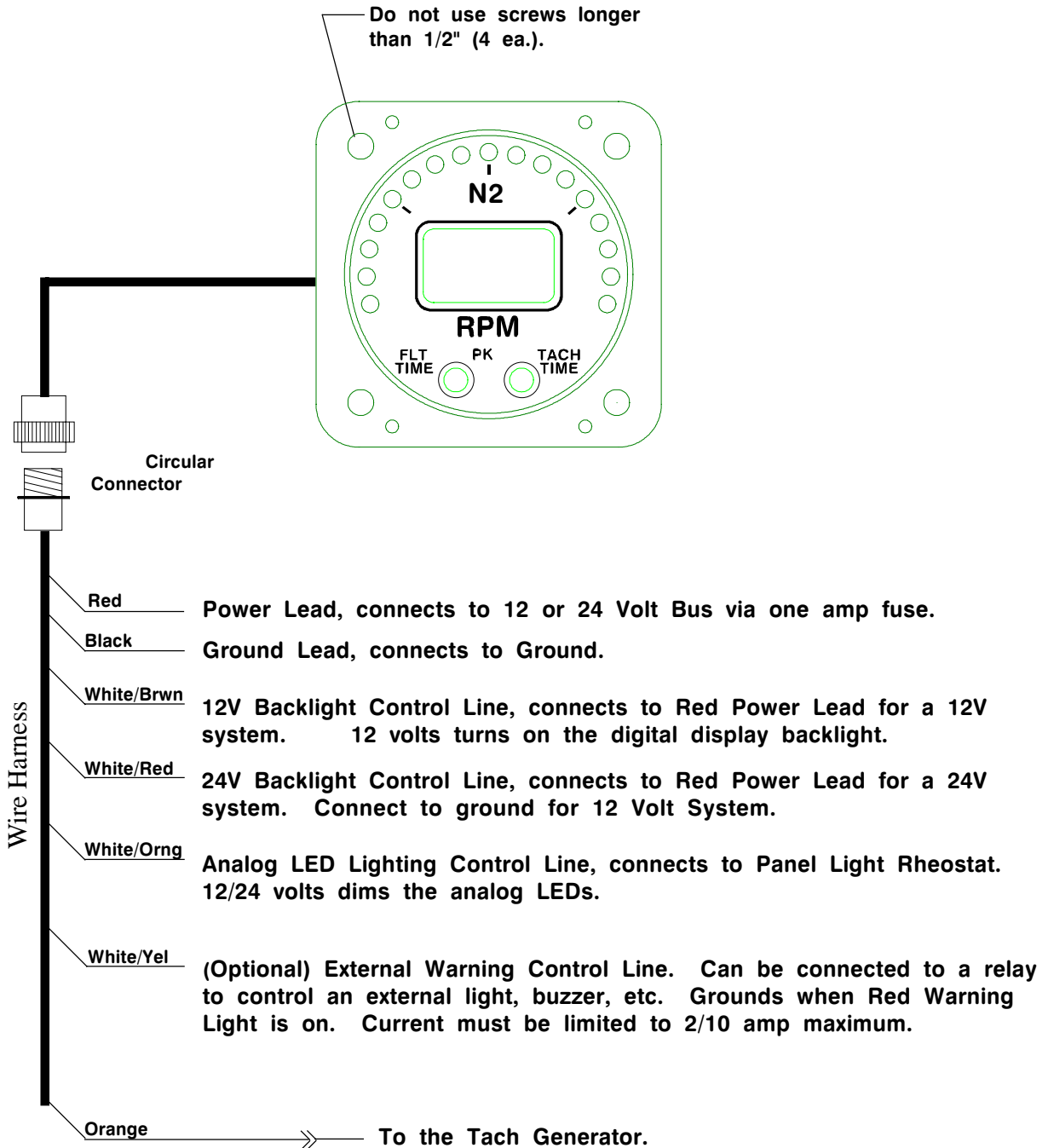

R-1-N2

Circular Connector

Connecting Cable Harness, Back View (wire side)

OR

Instrument Connector, Front View

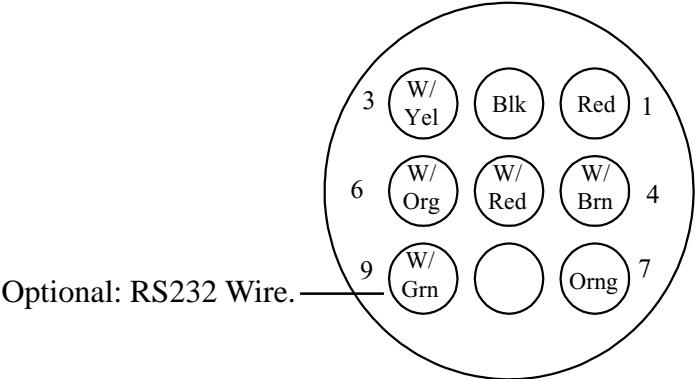

Connecting the R-1-N1 or R-1-N2 to a Walters Tach Generator

0625011
6/25/01

Top View
Tach Generator Connector

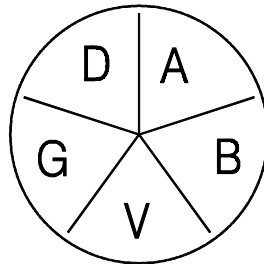

1. Connect pin \hat{V} to Ground.
2. Connect pin \hat{A} to the R-1-N1 orange lead.

Note: Any two pins (A, B or V) may be used. Ground any one pin and connect any other to the R-1-N1 orange lead. Outputs on some Tach Generators can become intermittent causing jumpy readings. You can test the Tach Generator by using an ohmmeter and checking for 35 ohms between any two pins (A, B or V).

Note: Do Not Use Pins \hat{G} or \hat{D} . These pins are floating and independent of the other pins.

Note: The signal out of the Walters Tach Generator can be noisy. If this is the case, a .1uF disc ceramic cap placed near the Tach Generator and across the two output leads will help.



Electronics International Inc. ®

63296 Powell Butte Hwy • Bend, OR 97701 • (541) 318-6060 • Buy-EI.com

