

Gyro Vacuum Functional Module (FM-Gyro) Installation Instructions and Wiring Diagram

1110982

II 1119981 Supplement (UBG-16)
II 0506931 Supplement (FP-5(L))

11/10/98

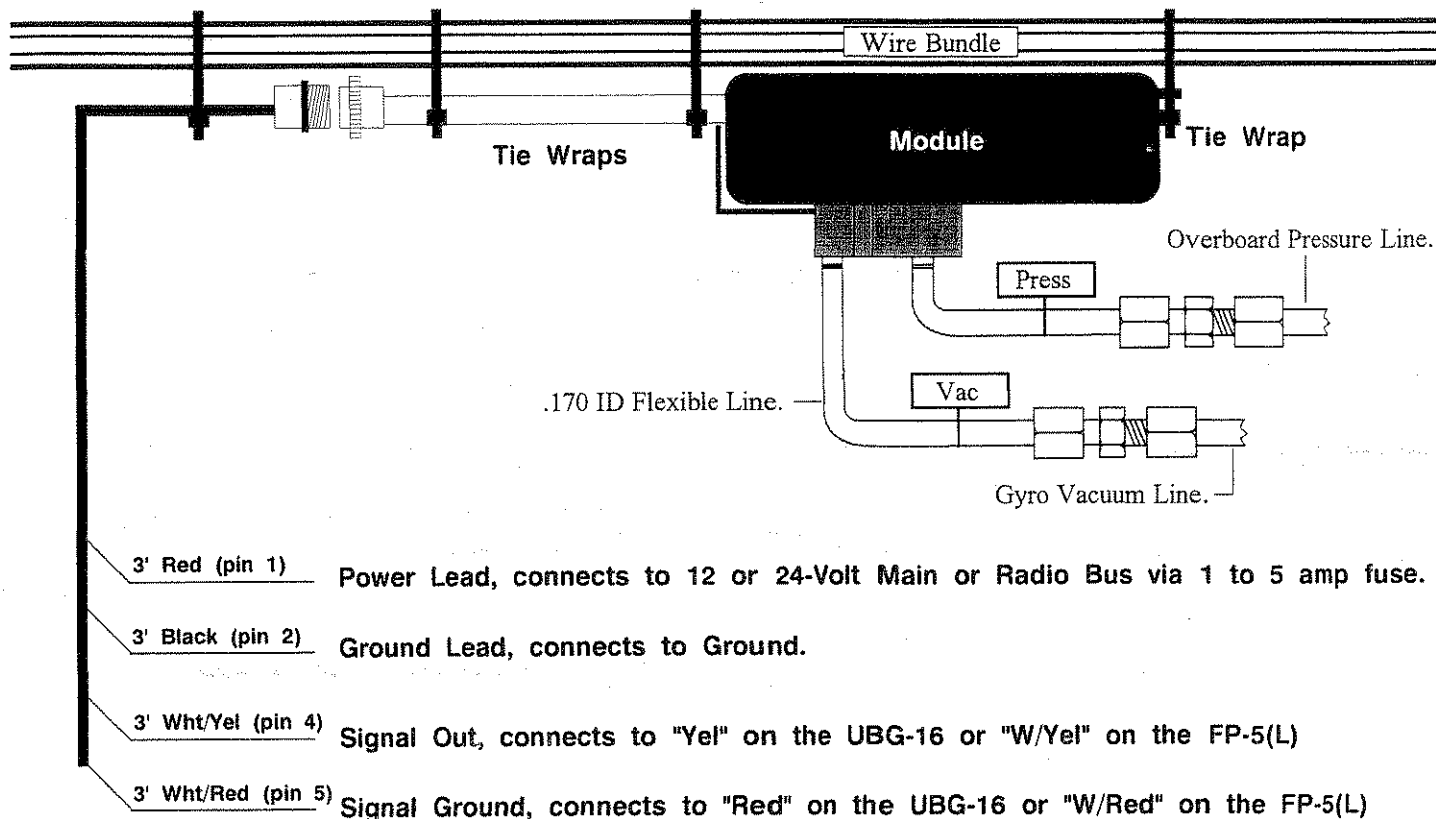

1. Mount the Module and Connect the 9-Pin Wire Harness:

Tie wrap the FM-Gyro Module to a wire bundle under the aircraft instrument panel. Connect the 9-Pin Wire Harness to the Module.

2. Route the Power and Ground Wires:

Route the red wire in the wire harness to the aircraft's 12 or 24-volt radio or main bus as applicable via a 1 to 5 amps fuse. Route the black wire in the wire harness to a good ground. Tie wrap these wires so they do not obstruct the freedom of travel of any controls.

3. Connect the Vacuum Pressure Line:

Connect the aircraft gyro vacuum line to the port tagged "Vac" on the FM-Gyro Module. Leave the port tagged "Press" open for non-pressurized aircraft. On pressurized aircraft connect the port tagged "Press" to the gyro overboard pressure line. Be sure these lines are tight. The ports are 1/4" flare union. Care should be taken not to put excess pressure on the flexible line between the flare union and the transducer mounted on the bottom of the module. The transducer ports can break. Make sure the flexible lines do not kink.

5. Route the Signal Out and Ground Wires to the UBG-16:

Route the White/Yellow wire to the appropriate left or right channel on the UBG-16 marked "Yel." Route and connect the White/Red wire to the appropriate channel on the UBG-16 marked "Red." Tie wrap all wires so they do not obstruct the freedom of travel of any controls.

UBG Extension Cable Harness (Left or Right)
Back View (wire side)

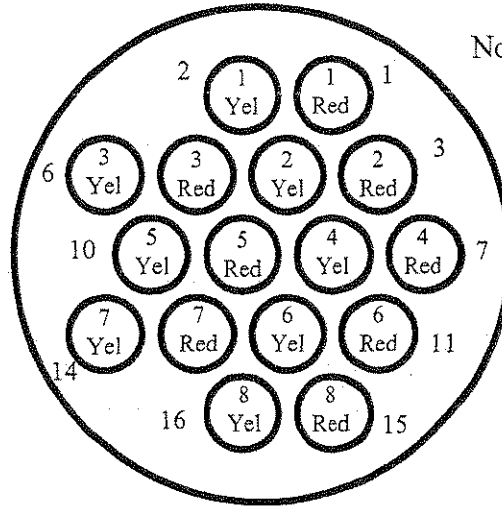

Note: 1 Red = Channel #1 Red wire (Gnd)
1 Yel = Channel #1 Yel wire (Signal)

6. Route the Signal Out and Ground Wires to the FP-5(L):

Route and connect the White/Yellow wire to pin 14 on the FP-5(L). Route and connect the White/Red wire to pin 12 on the FP-5(L). Tie wrap all wires so they do not obstruct the freedom of travel of any controls.

FP-5(L) Extension Cable Harness, Back View (wire side)

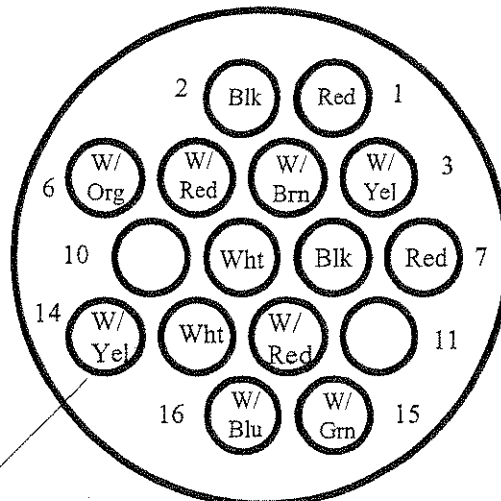

12 through 14 connects to
a Functional Module

Specifications and Operating Features

Model:

FM-Gyro (Gyro Vacuum Functional Module)

Case Dimensions:

3" x 2" x 1"

Weight:

Module Only: 2.8 Oz.

Environmental:

Meets TSO C45.

Power Requirements:

7.5 to 35 Volts, 1/10 Amp.

Accuracy:

2% or better in accordance with TSO C45.

Resolution:

.1 in Hg.

UBG Display Range:

+/- 99.9" Hg.

Pressure Transducer Limitations (05DN):

Normal Operating Range: 0 to 5 psi.

Proof pressure: 20 psi. Max.

Common Mode Pressure: 50 psi. Max.