

The Pilot's Manual

for

Leaning and Diagnosing Engine Problems

4/21/04, Copyright E.I. inc., All rights reserved, Ron Roberts

04210401
Rev. E: 9/8/04

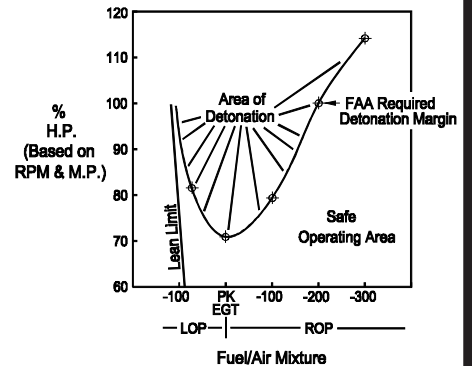
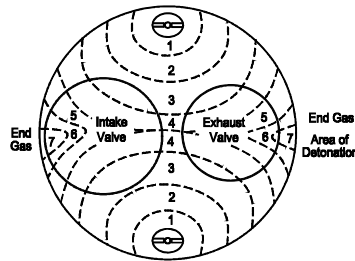
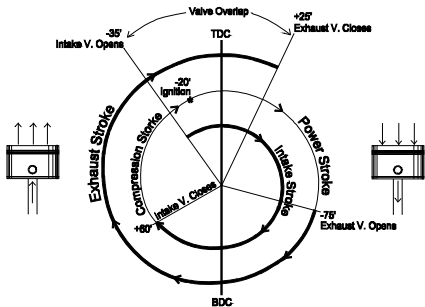
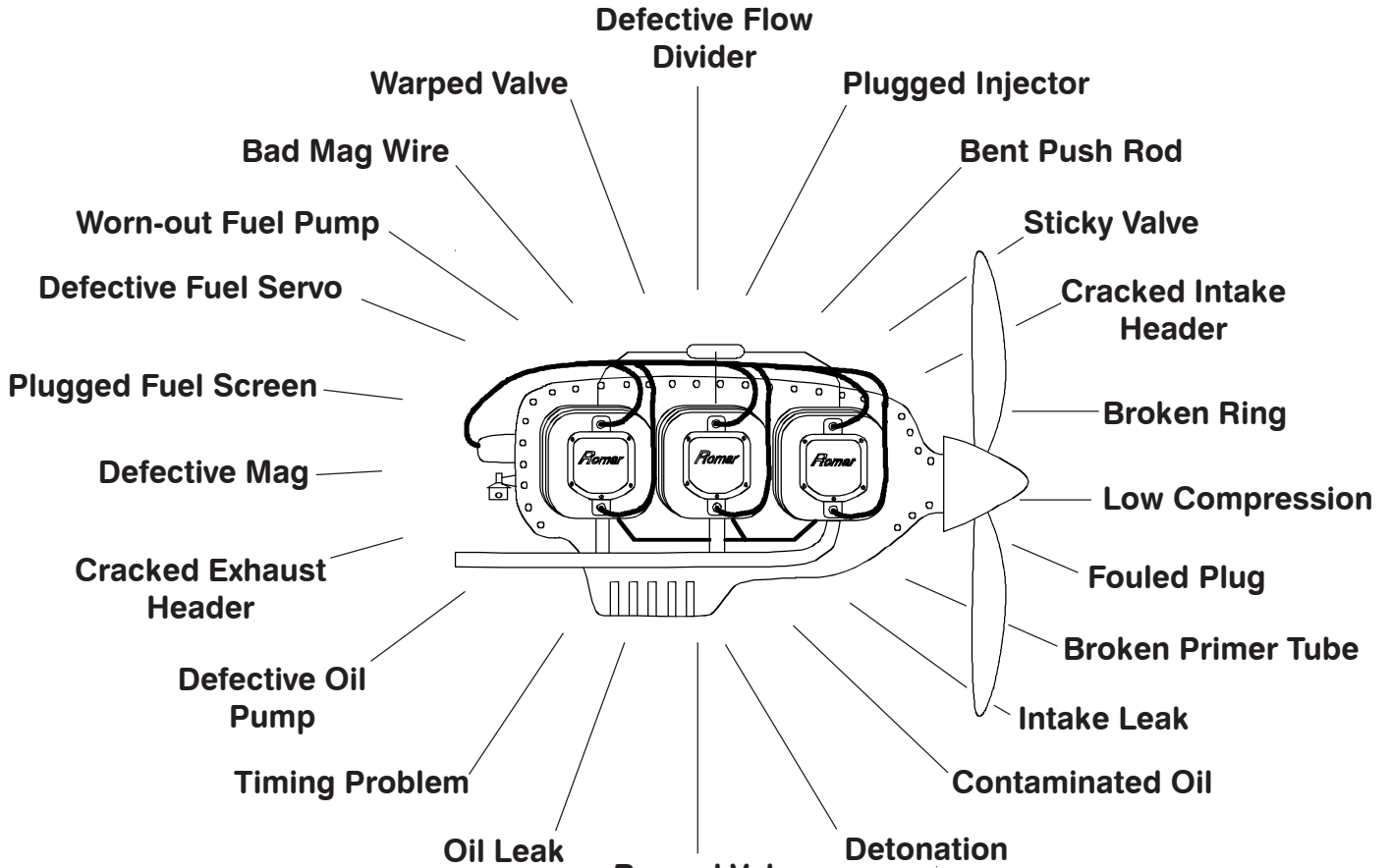

Electronics International Inc.®

63296 Powell Butte Hwy • Bend, OR 97701 • (541) 318-6060 • www.Buy-EI.com



Contents

Preface	1
The Four Strokes of an Engine	2
Intake Stroke	2
Compression Stroke	4
Power Stroke	5
Exhaust Stroke	7
Maintenance Shop Survey	8
Results of the Survey	8
Exhaust Valves	9
Life Expectancy of an Exhaust Valve	10
Detonation	11
The Affects of Engine Parameters on Detonation and Pre-ignition	13
Mixture Control and Throttle	13
Deposits in the Combustion Chamber	14
CHT	15
Inlet Air Temperature	15
Timing	15
RPM	15
Humidity, Fuel, Compression Ratio	15
Leaning Methods	15
Idle and Taxi	16
Takeoff and Climb	17
Cruise	18
Descent	19
A Great Engine Analyzer	21
Engine Diagnostics	23
Diagnosing Problems from the EGT Readings	23
Diagnosing Problems from the CHT Readings	26
Engine Tests	27
Engine Problems	28
Engine Diagnostic Reference Guide	i
Base Line Comparison Test	ii
Lean Range Test	iii
Mag Test	iv
Intake Leak Test	v
Fuel Flow / Horsepower Test	vi
References	vii

Preface

The data presented in this manual is intended to help pilots formulate safe leaning techniques and to perform engine diagnostics. The data presented is based on published experiments by leading researchers, professors, PhD's, scientists and engineers in the field of internal-combustion engines. When material is referenced, it will be shown as follows:

Example: (*Ref.* Taylor, 23)

- "*Ref.*" - Indicates a reference is cited.
- "Taylor" - Author's name. The bibliography at the back of this manual will list the works cited, by author's name.
- "23" - See page 23 in the work cited.

As everyone knows, appearances can be deceiving. It is a fact that an engine can be operated in a particular manner which may not appear to cause damage. This can be misleading. Most engine damage does not occur all at once. If a pilot operates an engine in a way that causes excessive heat, stress or wear, it may take months before damage to the engine is severe enough to be detected by the pilot. In order to formulate safe operating procedures, it's important to use sound engineering data.

Who holds the engineering data? It seems logical that Lycoming and Continental would. After all, most of us are flying with the engines designed by these companies. Both companies do produce a good amount of information on how to operate an engine safely, but they actually offer little in the way of supporting engineering data. Without technical data from the engine manufacturers and because of new operating procedures available from other sources in the industry, many pilots have questions about how to safely operate their engines. Fortunately, there are many excellent engineering studies, technical papers and engineering books that can provide the data necessary to formulate sound operating procedures.

This manual is divided into seven sections:

The Four Strokes of an Engine: This section describes the four operating strokes of an aircraft engine (Intake, Compression, Power and Exhaust). Technical data is provided for each of the operating cycles.

Maintenance Shop Survey: This section answers the question, "Are there engine maintenance problems that may affect the way an aircraft engine is operated? We learn that exhaust valve problems are one of the main reasons for a top overhaul.

Exhaust Valves: In this section, some issues surrounding exhaust valve failures are described, as well as some operating procedures to help prevent them.

Detonation: This section describes detonation, its detrimental effects on an engine, its causes, the likelihood of it occurring, and how to help prevent it.

Leaning Methods: This section covers a number of leaning methods during the climb, cruise and descent operation of an aircraft.

A Great Engine Analyzer: This section describes features that separate a good engine analyzer from a *great* engine analyzer. It also describes how a great engine analyzer can be one of the *most effective* tools for avoiding engine problems and adding a significant level of safety to any flight.

Engine Diagnostics: This section sets forth information helpful in diagnosing most “Top End” engine problems. Also provided are engine tests to help finding problems and an “Engine Diagnostic Reference Guide.”

The Four Strokes of an Engine

This section helps explain from a technical point of view how an engine works. If you’d like a better understanding of terms frequently used in discussions about engines, you’ll probably find this section interesting. If you find technical terminology boring or more than you care to know about, just skip this section. The following discussion is targeted for aircraft engines operating at 65% to 100% power. We will review the four operating strokes (cycles) of an engine and discuss the processes and issues associated with each cycle.

Intake Stroke:

The objective of the intake stroke is to ingest as much charge (fuel/air mixture) into the combustion chamber as possible (or as the throttle will allow). Also, it is desirable for the intake stroke to produce some turbulence to help mix the fuel with air to deter detonation.

The intake valve starts to open during the last portion of the exhaust stroke. As the exhaust gasses exit the exhaust port, they’re accelerated and have inertia (a force that keeps the gasses flowing in the same direction). As the intake valve opens (approximately 35 degrees before the piston reaches top-dead-center “TDC”), the exiting exhaust gasses continue to flow out the exhaust port. This helps to keep the pressure in the combustion chamber low so the intake charge can be drawn into the cylinder as the exhaust gasses continue to vacate (see Fig. 1).

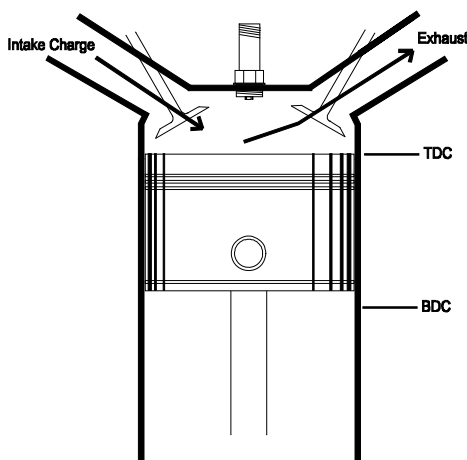

Fig. 1: Shows the exhaust exiting the cylinder at the end of the exhaust stroke and during the start of the intake stroke.

Any exhaust gasses left in the cylinder after the exhaust valve closes will dilute the next incoming charge, rob the engine of power and increase *cycle-to-cycle variations* (Ref. Stone 181, 295). Increasing the cycle-to-cycle variations in the combustion process limits the leaning range and the engine’s ability to deter detonation for a given mixture and throttle setting (see Fig. 2). Cycle-to-cycle variations are greater when operating on the lean side of peak EGT.

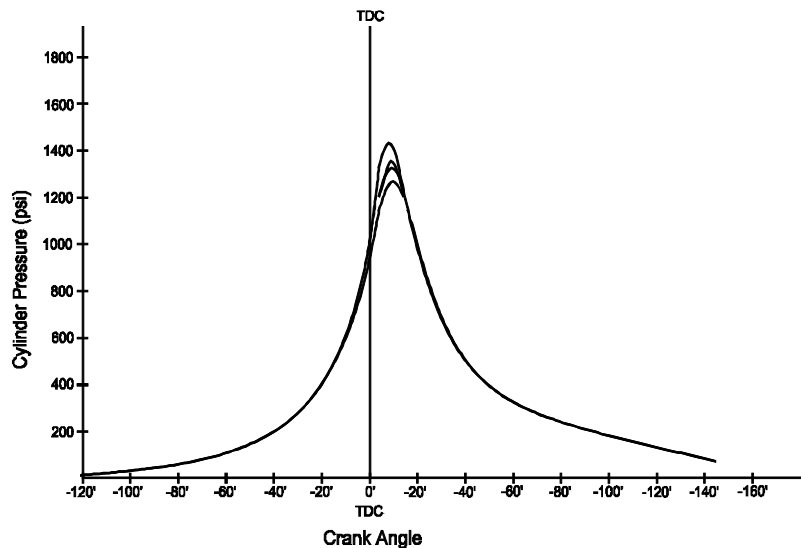

Fig. 2: Typical cycle-to-cycle variation when operating on the lean side of peak EGT (LOP).

As the piston moves downward and the exhaust valve closes, the intake charge will accelerate to maximum velocity of less than 0.6 *Mach Index* (for most aircraft engines) as it passes through the intake port. The velocity of the incoming charge has the predominate effect on the *volumetric efficiency* of an engine (*Ref. Stone, 288; Lumley, 23*). It's interesting to note that the RPM that produces the maximum volumetric efficiency also produces the maximum torque (i.e., the more charge in the cylinder, the more torque produced). Also, the intake charge helps keep the intake valve cool.

Some aircraft engines use shrouded port intake geometry. This produces *swirl* as the intake charge enters the combustion chamber (see Fig. 3). Swirl helps mix the fuel and air to produce a homogeneous charge, which causes the burn rate to increase, thereby reducing cycle-to-cycle variations and detonation (*Ref. Stone, 154, 345; Taylor2, 31; Lumley, 140, 148+*).

Definition of terms:

Cycle-to-cycle variations - Variation in the peak pressure from one engine cycle to the next. Cycle-to-cycle variations can account for a 10% decrease in power output for a lean mixture.

Mach Index - The ratio of the calculated velocity of the intake charge at the smallest cross section to the speed of sound.

Volumetric Efficiency - The volume of the intake charge delivered to the engine compared to the theoretical volume the engine could take.

Swirl - The circular action of the charge during the intake stroke.

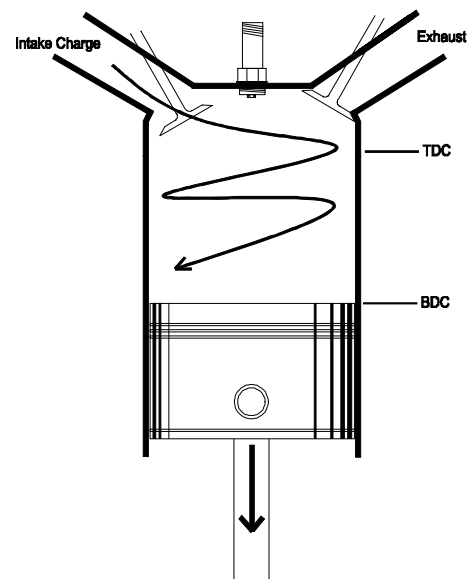

Fig. 3: Shows the swirling pattern of the fuel/air charge during the intake stroke.

Compression Stroke:

The objective of the compression stroke is to compress the intake charge, ignite the charge at the proper time to produce the maximum power (for the given throttle) and to provide some mixing of the fuel to deter detonation.

As the piston travels upward from bottom-dead-center (BDC), the intake valve closes approximately 60 degrees **after** BDC. At this point the piston has traveled 23% of its total stroke. The cam is designed so the intake valve will shut before the pressure in the cylinder exceeds the pressure in the intake manifold.

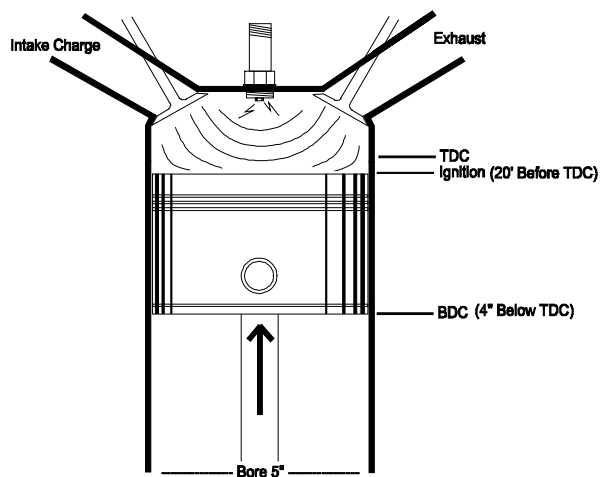

Fig. 4: Shows the position of the piston (20° before TDC) when the spark plug is ignited.

At approximately 20 degrees before TDC the spark plug will ignite the charge (see Fig. 4). Aircraft engines have fixed ignition timing (the timing does not change as in automotive engines). The exceptions to this are the LASAR and the FADEC systems. The optimum ignition timing is called “Maximum Brake Torque” timing or MBT timing (Ref. Stone, 73; Heywood, 374).

Interesting data presented by Heywood (page 445) shows that increasing the discharge current and duration of the spark has no significant effect on engine operating characteristics, unless operating at the richest or leanest settings. Once the charge (fuel/air mixture) is ignited, it will burn at a rate (flame speed) influenced by the following factors:

RPM - As engine RPM increases, the flame speed increases proportionally. Approximately 2 degrees spark advance is needed to maintain optimum ignition timing (MBT) from cruise to high engine RPM. The fact that the flame speed increases proportionally as the engine RPM increases is one of the most important characteristics that allows high RPM spark ignition engines to run (Ref. Heywood, 828).

Altitude - At higher altitudes, the flame speed increases slightly (Ref. Taylor², 20). Optimum timing is slightly advanced as altitude increases.

Mixture - Leaning has the most effect on optimum timing (MBT). The fastest flame speed is at the best power setting. At a full rich mixture the flame speed slows by approximately 5% from best power. At approximately 75°F lean of peak EGT, the flame speed slows by approximately 12 degrees from best power (Ref. Taylor², 23). This is one of the reasons there is a noticeable drop in power when operating lean of peak. This drop in power can be lessened by advancing the spark timing 8-12 degrees when operating LOP, which is where the aviation industry is heading.

Figure 5 shows the pressure curve for the compression and power stroke with the spark timing at optimum (MBT). Peak pressure will occur approximately 17 degrees past TDC. If the spark timing is advanced from optimum (MBT), a higher peak pressure will occur closer to TDC, less torque will be produced, cylinder head temperatures (CHTs) will *increase*, exhaust gas temperatures (EGTs) will slightly *decrease* and the chance of

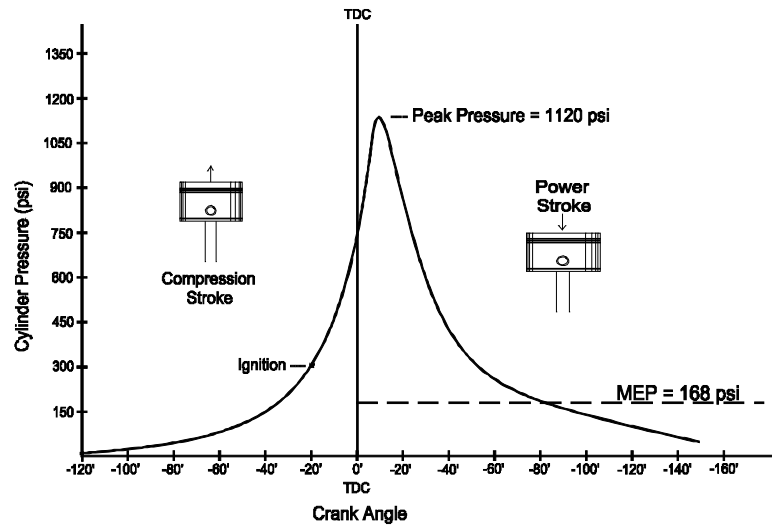

Fig. 5: Shows the calculated pressure curve for a O470 engine.

detonation will *increase*. If the spark timing is retarded from optimum, a lower peak pressure will occur further from TDC, less torque will be produced, CHTs will *decrease*, EGTs will *increase* and the chance of detonation will be *reduced*.

Most aircraft engine timing is set for optimum (approximately 20 degrees before TDC) at best power mixture. Therefore, LOP and ROP operation have a slightly retarded timing from optimum. This has a tendency to reduce the chance of detonation at LOP and ROP operation.

Power Stroke:

The objective of the power stroke is to convert the temperature and pressure from combustion into torque.

The intake charge is ignited approximately 20 degrees before the piston reaches TDC. As the intake charge burns, pressure in the cylinder is produced slowly. Just before TDC there is little additional pressure in the cylinder due to combustion. This is called the *delay period* (Ref. Stone, 72). The most significant rise in pressure is produced *after* TDC. Peak pressure occurs approximately 17 degrees past TDC (see Fig. 5). Flame travel across the cylinder is over 90% complete when peak pressure occurs (Ref. Taylor2, 24; Lumley, 8+). The peak pressure is the predominant force producing torque. We can calculate a 260hp O470 engine with an 8.5:1 compression ratio as having a 1120 psi peak pressure. That equates to 11 tons of force on the combustion chamber, top of the piston, connecting rod and crankshaft when peak pressure occurs.

A simpler way to represent the pressure in an engine is by using the engineering term BMEP (brake mean effective pressure). BMEP is the constant pressure on the cylinder during the power stroke required to produce the same torque as the engine produces when running. BMEP can be used to compare engines and correlate technical data. We can calculate a 260hp O470 engine with a 5" bore and 4" stroke (using the formula $BMEP = \frac{HP \times 793000}{Displacement \times RPM}$) as having a 168 psi BMEP and a torque of 525 ft-lbs.

One of the most effective ways a designer can increase an engine's power is to increase the engine's compression ratio. Most aircraft engines have a compression ratio from 7.0:1 to 9.0:1 (Ref. Avco Lycoming, 1+). As compression ratios increase so do horsepower, efficiency and the chance of detonation. Detonation will be covered in a later section.

Another way of looking at the power stroke is from a thermodynamic point of view. This view offers advantages when dealing with EGTs and CHTs, which we will cover in a later section. During the intake stroke a fuel/air mixture charge is ingested into the cylinder. This charge has a given amount of energy. As the intake charge burns, the fuel/air mixture is converted to heat energy. The combustion chamber will reach a peak temperature of around 4000°F. As the piston is pushed downward and torque is produced, heat energy is converted to mechanical work causing the combustion temperatures to drop dramatically. The unused heat energy is exhausted and can be measured with an EGT instrument. Through convection and radiation some of the heat from combustion is transferred to the combustion chamber, increasing the CHTs and oil temperature.

The amount of fuel required to produce a given amount of power is approximately the same for most aircraft engines. *Specific fuel consumption* is a measurement of an engine's efficiency (fuel required to produce power) and is displayed in Lbs/Hr.- H.P. or Gal/Hr - H.P. (see Fig. 6). Most aircraft engines require .11 Gal/Hr. - H.P. at full rich mixture. In other words, a 260 H.P. engine requires approximately (.11 x 260) 28.6 Gal/Hr fuel flow for a sea level takeoff. At 75% power and full rich mixture, this same engine requires (.11 x .75 x 260) 21.4 Gal/Hr (Ref. Taylor2, 184).

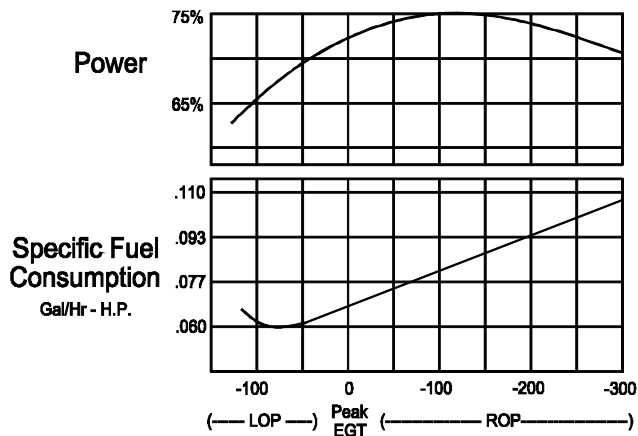

Fig. 6: Typical power curve and specific fuel consumption for most aircraft engines.

At best economy mixture, the same 260 H.P. aircraft engine burns approximately .06 Gal/Hr - H.P., or 45% less fuel than at full rich mixture. In other words, when operated at 75% power and with a best economy mixture this engine burns (.06 x .75 x 260) 11.7 Gal/Hr. If an engine's fuel/air distribution from cylinder to cylinder is not perfect, its actual fuel burn will be higher than calculated above.

Exhaust Stroke:

After combustion, the objective of the exhaust stroke is to vacate as much of the leftover gasses as possible in preparation for the next intake stroke.

Approximately 75 degrees before BDC on the power stroke the exhaust valve starts to open (see Fig. 7). This early opening of the exhaust valve is needed to expel gasses left after combustion. Exhaust residues and incomplete mixing of the fuel/air charge is a significant contributor to cycle-to-cycle variations, which lower the maximum power, decrease efficiency and narrow the leaning range of an engine. (Ref. Stone, 295; Taylor2, 29+).

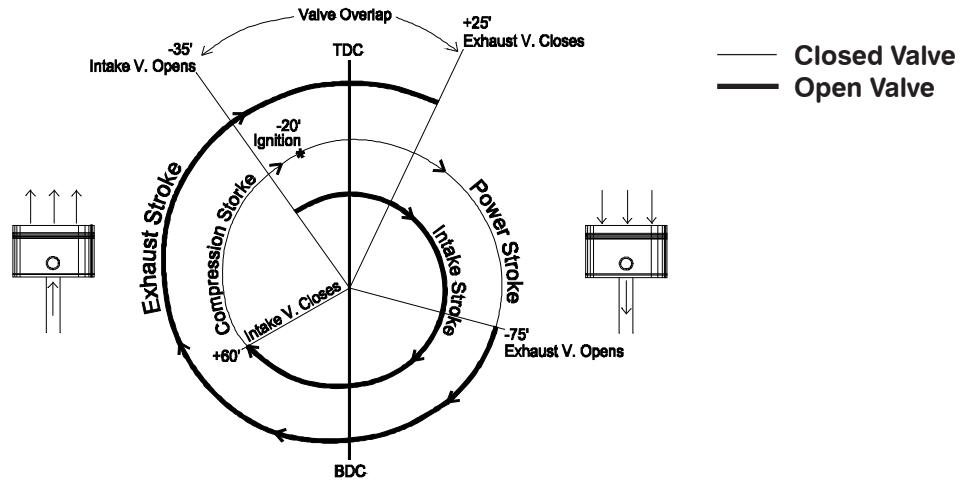

Fig. 7: Typical valve timing diagram.

Shortly after the exhaust valve opens the exhaust gas flow rate will be at its highest level. As the exhaust valve opens the exhaust gas temperature at the exhaust port will increase from approximately 900°F to 1400°F and will remain fairly constant for the entire time the exhaust valve is open. An exhaust valve gets hot from the high velocity and temperature of the exhaust gasses and from the length of time the valve is open.

To measure exhaust gas temperatures, an Electronics International's EGT probe is normally placed 1 1/2" down from the exhaust port. Because of the high flow rate of the exhaust gasses, the temperature of the EGT probe takes on the peak temperature of the exhaust gasses within seconds. The harsh environment of the high velocity EGT gasses may cause reliability problems for some competitors' EGT probes. E.I.'s EGT probes are manufactured from high temperature proprietary stainless/inconel material and **will not burn out!** Electronics International manufactures EGT probes with two different sized tips for aircraft engines, and very small exposed tip EGT probes for race dynos.

Maintenance Shop Survey

Before discussing any leaning techniques, it is important to get a feel for the kind of engine problems maintenance shops routinely deal with. Because aircraft engines have problems associated with the way they are operated, this needs to be taken into consideration when discussing leaning techniques.

Our survey targeted maintenance shops that performed engine maintenance on a regular basis and performed top overhauls. We called most shops advertising in trade magazines or flyers. In some cases shops sent cylinders out to facilities that specialized in cylinder head repairs. These facilities repair hundreds of cylinders every year for maintenance shops all over the country. We also surveyed these facilities.

The survey was conducted as an open forum. We started by asking two questions: “When you were called upon to perform unscheduled maintenance on an aircraft engine, what was the problem, and what do you think caused it?” These questions resulted in a lengthy conversation that covered everything from manufacturing defects to problems caused by pilot operation. We limited the results of this survey to engine problems which a pilot caused or contributed to.

The maintenance shop owners’ level of knowledge and years of experience in their profession is impressive. Many have a true passion for what they do. All of the shop owners we talked to see many engine problems and they were very aware of the current lean-of-peak operating procedures. We felt their experience and advice should be presented here.

Results of the Survey:

One hundred percent of the shops reported that excessive EGTs and/or CHTs cause engine damage on a regular basis. Following is a list of some of the problems they reported:

- * Sticky valves due to excessive heat, causing oil to bake onto the valve stems.
- * Burnt exhaust valves caused by excessive heat and/or sticky valves.
- * Extensive exhaust valve guide wear due to heat. Also, guide wear allows the hot exhaust gasses to leak up between the valve stems and the valve guides, causing the valves to stick.
- * Excessive ring wear caused by detonation and/or excessive heat. Ring wear can cause the rings to leak. This can foul the plugs due to excessive oil in the cylinders. Also, compression can drop and the oil may turn black quicker than normal.
- * Cracks and heat damage to the ring lands caused by detonation.
- * Cracks in the cylinder heads around the exhaust ports, injector ports and spark plugs caused by excessive heat and/or detonation.
- * Every year some shops see holes burned in the top of the pistons, bent or broken valves, broken rings, and damage to the piston pins, main bearings or connecting rods.

One hundred percent of the shops reported a pilot's leaning technique as the main contributor (if not the single cause) of excessive EGTs and/or CHTs in an engine. Interestingly, when the shops were asked what leaning technique they recommend, they all had the same answer: for a Continental or Lycoming engine, at cruise power or less, lean 100°F rich of peak EGT. Their combined reasoning goes something like this:

*An aircraft engine is air-cooled and therefore runs **hot**. It does not have the advantages of a water jacket to control the heat at strategic spots around the cylinder heads. Also, an aircraft engine does not have a detonation detector, oxygen sensor or a computer to control timing or fuel/air mixture based on throttle position, temperatures, detectors or sensor inputs. If a pilot chooses, an aircraft engine can be run at temperatures that will significantly reduce the life of some of its parts and there is no automatic system or computer to prevent or limit engine damage.*

If long engine life is to be achieved, engine power and mixture must be controlled. By leaning to best power (100°F rich of peak EGT) at cruise power or less, you will obtain a higher airspeed and reduce your time in flight. This has value. In addition, by leaning to best power you will be placing your EGTs and CHTs at acceptable levels that are easy to maintain and you will achieve good engine life. This also has value. It's simple, it's easy and it works. The additional expense in fuel is worth the value gained.

Whether or not you agree with their leaning recommendations, it's obvious that controlling the power and temperature in an aircraft engine should be a consideration when establishing a leaning technique.

Exhaust Valves

Many mechanics report that the most common reason for unscheduled engine work is exhaust valve problems due to excessive heat. It's necessary to address the issue of overheated exhaust valves before good leaning techniques can be established.

During the power stroke the high temperatures of combustion (approximately 4000°F) cause the exhaust valves to absorb heat through convection and radiation. The amount of heat absorbed during the power stroke is not as significant as the heat absorbed during the exhaust stroke.

During the exhaust stroke the high velocity of the exhaust gasses and the large surface area of the exhaust valve head cause the exhaust valve to absorb a significant amount of heat. The temperature of the hot exhaust gasses (EGTs) flowing over the valve has a direct affect on the temperature of the exhaust valve. The exhaust valve is heated during two of the four strokes of the engine (power and exhaust strokes). During the exhaust stroke, the valve loses its major cooling path (valve seat face to the seat insert).

Seventy-five percent of the cooling of the exhaust valve is done through the valve seat face to the seat insert (Ref. Taylor², 531), which is cooled by the cylinder head. As the cylinder head temperature increases, the temperature difference between the exhaust valve seat face and the seat insert is reduced. This reduces the cooling capability of the seat insert on the exhaust valve, increasing the exhaust valve temperature. Cylinder head temperatures (CHTs) have a direct affect on the temperature of the exhaust valves.

Twenty-five percent of the cooling of the exhaust valve is through the valve stem (Ref. Taylor2, 531). The stem is long and relatively small compared to the exhaust valve head. These features make the exhaust valve stem a poor heat sink. Most of Lycoming's exhaust valves are sodium filled. Sodium turns to a liquid at 208°F and is a good conductor of heat. For this reason Lycoming's sodium-filled valves run cooler than Continental's solid-stem valves.

Exhaust valve stems are cooled by the transfer of heat through the valve guides to the cylinder heads. Cylinder head temperatures (CHTs) have a direct effect on the temperature of the valve stems. Oil is delivered to the top of the valve stem to lubricate the valve guides.

Excessive heat from high EGTs and CHTs can accelerate exhaust valve guide wear. As the valve guide wears, the heat transfer from the valve stem to the guide is reduced, causing higher valve temperatures. This causes additional valve guide wear and can lead to a stuck valve, a burned valve, or valve failure.

Lycoming and Continental use a method called valve pinch to reduce carbon deposits on the exhaust valve seat faces and seat inserts. The exhaust valve seat face is ground from ½ to 1 degree less than the face of the seat insert. This increases the valve pressure at the outside of the valve seat face when the exhaust valve is closed. This increased pressure helps to cut through deposits forming as the exhaust gasses pass by the valve and insert faces.

If for any reason the exhaust valve leaks during combustion, super hot combustion gasses will leak by the exhaust valve causing it to overheat and burn in a very short time. Proper seating of the exhaust valve is critical to valve life.

Life Expectancy of an Exhaust Valve:

Both EGT and CHT have a direct affect on the exhaust valve temperature. If the life expectancy of an exhaust valve for every EGT and CHT combination and for every engine was known, it would be easy to determine an engine operating parameter that would help achieve the desired exhaust valve life. Since we do not have this information, it's necessary to rely on experience in formulating acceptable engine operating parameters.

Heat is the main concern when it comes to the life of an exhaust valve. Even a small reduction in the exhaust valve temperature results in a marked improvement in valve life and reliability (Ref. Taylor2, 531). It doesn't matter whether the EGT and CHT heat was produced by running an engine on the lean side of peak EGT (LOP) or on the rich side of peak EGT (ROP).

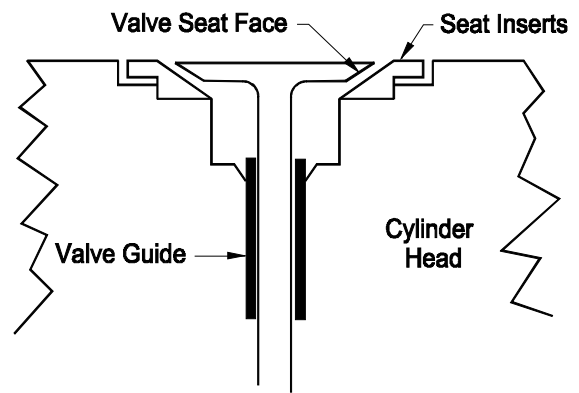

Fig. 8: Shows an exhaust valve, seat and guide.

The relationship between the exhaust valve life and the *sum* of the EGT and CHT is shown in figure 9. Both the EGT and the CHT has a direct affect on the exhaust valve temperature, as pointed out in the text above. If the EGT goes up, the CHT must come down to keep the exhaust valve at the same temperature. It is uncertain what the EGT+CHT sum is at any given point on the graph. The data can be bracketed by getting somewhat close at the two ends of the graph as shown in figure 9.

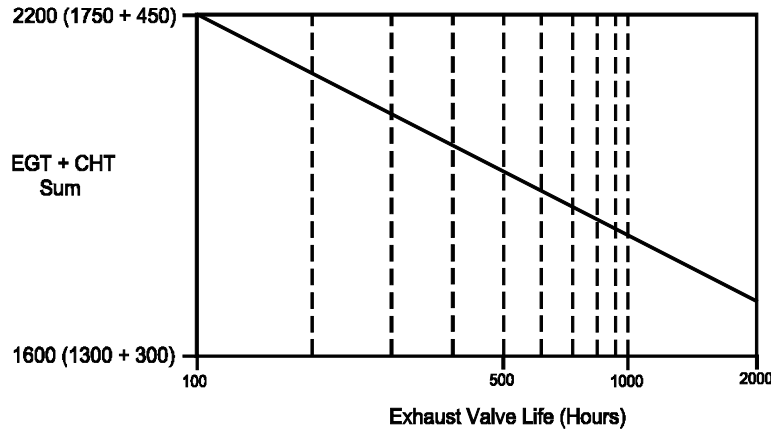

Fig. 9: Shows the affects of heat on the life of an exhaust valve.

When establishing a leaning technique we must take into consideration the effects of EGTs and CHTs on the exhaust valves. We do know that the higher the EGT+CHT sum, the shorter the life of the valve.

Detonation

Detonation can cause serious engine damage and therefore is the single largest factor in limiting engine power. More research has been devoted to the study of detonation than any other aspect of the spark combustion engine (*Ref. Taylor2, 34*). All aircraft engines are capable of detonation. Detonation and power go hand in hand. If an aircraft engine is to make a reasonable amount of power (for its given size), it must be designed at or near its detonation margin. The FAA sets the minimum detonation margin for all aircraft engines.

One of the inherent features of an aircraft engine which makes it susceptible to detonation is its large bore size (*Ref. Taylor2, 78*). Figure 10 shows the relationship between bore size and detonation. For example, the Continental O470 engine has a 5" bore and a lawnmower engine has a bore size in the 2"

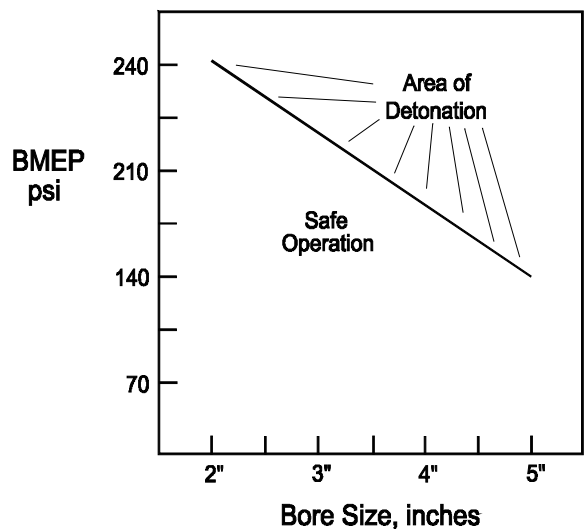

Fig. 10: Affects of cylinder size on detonation. Study by Taylor at MIT. Compression Ratio = 8:1 This graph is only specific to the engines used in the study.

range. As figure 10 shows a 5” bore engine will detonate at approximately half the cylinder pressure as a 2” bore engine will. Also, the cylinder-surface temperatures increase as the bore size of the engine increases. This also contributes to detonation in large bore engines. This is one reason a large bore engine requires more care in its operation in order to lengthen its life.

Unfortunately it is easy to operate an aircraft engine in a manner that will produce detonation and engine damage. It is up to the pilot to operate the engine in a manner which will prevent detonation. Let’s take a look at detonation and what a pilot can do to help avoid it.

What is Detonation?

Once the fuel/air mixture (charge) is ignited in the combustion chamber the charge will burn at a uniform rate. The last portion of the charge to burn (called “end gas”) is where detonation will occur (see figure 11). When cylinder pressure is high (produced by power) and surface temperature at the location of the end gas is high, the end gas

will auto-ignite and burn at a rapid rate (Ref. Heywood, 375). This causes the peak pressure in the cylinder to occur early and spike to a level which can be 10 -50% higher than normal. Detonation can cause the pressure in an O470 engine to go from 11 tons to over 15 tons.

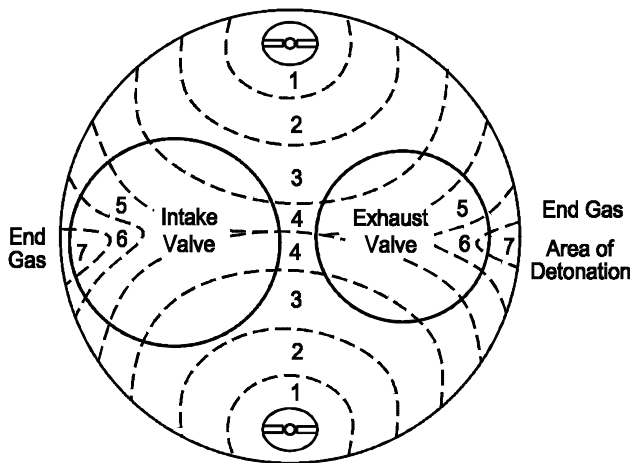

Fig. 11: Burn pattern for a Continental O470 combustion chamber.

Cycle-to-cycle variation in combustion can move an engine’s operation in and out of detonation. As detonation increases the peak cylinder pressure, it also increases the surface temperatures in the area in which detonation is occurring. This increased pressure and heat causes detonation to get worse. Over time this may result in a run-away condition and engine damage. If left unchecked, this runaway condition can lead to pre-ignition. Pre-ignition is self-ignition of the charge before the spark plug has a chance to ignite the charge. Pre-ignition causes extreme heat and pressure in a cylinder, which also contributes to detonation and a

runaway condition (Ref. Stone, 75).

During light (incipient) to medium (limiting) detonation the EGT will *decrease* slightly and the CHT will *increase* slightly. Although this situation most likely will go unnoticed, it is an indication that heat energy is being transferred to susceptible parts in the combustion chamber. Detonation can cause engine damage through two mechanisms:

Excessive Cylinder Head Pressure - Excessive pressure in a cylinder produced by detonation can cause cracks at the spark plug hole, injector port and exhaust valve port, broken rings and broken ring lands. These kinds of serious problems are not uncommon.

Excessive Heat Transfer - When detonation occurs the end gas will burn approximately 5 to 25 times faster than normal (*Ref. Heywood, 375*). This rapid burn produces a pressure wave (around 5,000 Hz.) that bounces off the walls of the cylinder and can be heard as a knocking sound in an automobile engine but cannot be heard in an aircraft engine (*Ref. Taylor2, 40+*).

This high energy pressure wave increases the transfer of heat of combustion (approximately 4000°F) to the top of the piston and the top of the exhaust valve. Heat damage can occur anywhere in the combustion chamber but early damage is usually localized to the area of detonation (see figure 12). Excessive heat causes local melting or softening of the metal and shows up as erosion or dimpling on the edge of the piston. Also, this excessive heat can warp or burn an exhaust valve or cause the valve to stick. In extreme cases, when pre-ignition is present, a hole can be melted through the top of the piston.

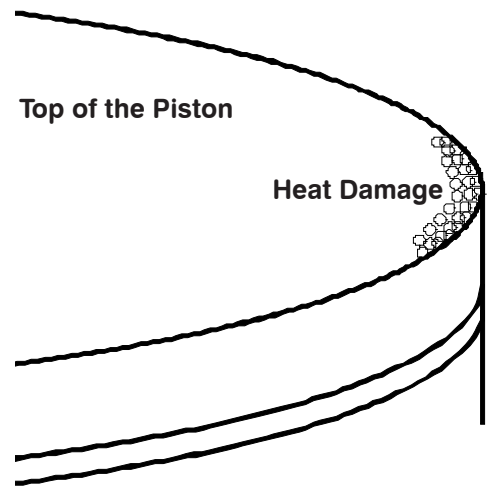

Fig. 12: Heat damage due to detonation.

Heat damage due to detonation may cause more problems than some pilots realize. Any sign of erosion or dimpling on the edge of a piston or exhaust valve is a serious matter which may require a change in leaning and/or operating methods. Trace detonation may not have a significant effect on an engine (*Ref. Heywood, 456*), but left unchecked it can lead to heavy detonation and engine damage. Again, a pilot should always operate an aircraft engine in a manner to *avoid* detonation.

The Affects of Engine Parameters on Detonation and Pre-ignition:

The following is a list of engine parameters and the affects they have on detonation and pre-ignition:

Mixture Control and Throttle: FAR 33.47 states “each engine must be tested to establish that the engine can function without detonation throughout its range of intended conditions of operation.” AC 33.47-1 outlines the detonation tests required by the FAA to T.C. an engine in an aircraft. These tests require an engine to operate without detonation with a 12% leaner mixture from full rich, at 100% power, maximum CHT and an OAT set for an FAA “Standard Hot Day.”

A study at MIT by Taylor and a study by Ford in 1982 show the fuel/air ratio (mixture) of an engine has a significant influence on detonation for a given throttle setting (*Ref. Taylor2, 69; Stone, 152*). Figure 13 is adapted from Taylor, Stone and AC 33.47-1 and shows the percent of power that will produce detonation for the full leaning range of a theoretical engine.

As figure 13 shows, an engine is most susceptible to detonation when operated at peak EGT. The FAA requires a 12% detonation margin when operating at 100% power. This represents a mixture setting of approximately 100°F leaner than a full rich mixture on the EGT instrument.

The area near the lean operating limit shown in figure 13 is a small operating range that may be able to support high power settings without detonation. The width of this lean operating window is set by the amount of turbulence in the combustion chamber during the compression stroke. Turbulence increases the detonation margin in an engine. (Ref. Stone, 152). Turbulence is produced by a high-domed piston, which most aircraft engines do *not* have. Also, moderate turbulence is produced by a hemispherical-shaped combustion chamber, which most aircraft engines *do* have.

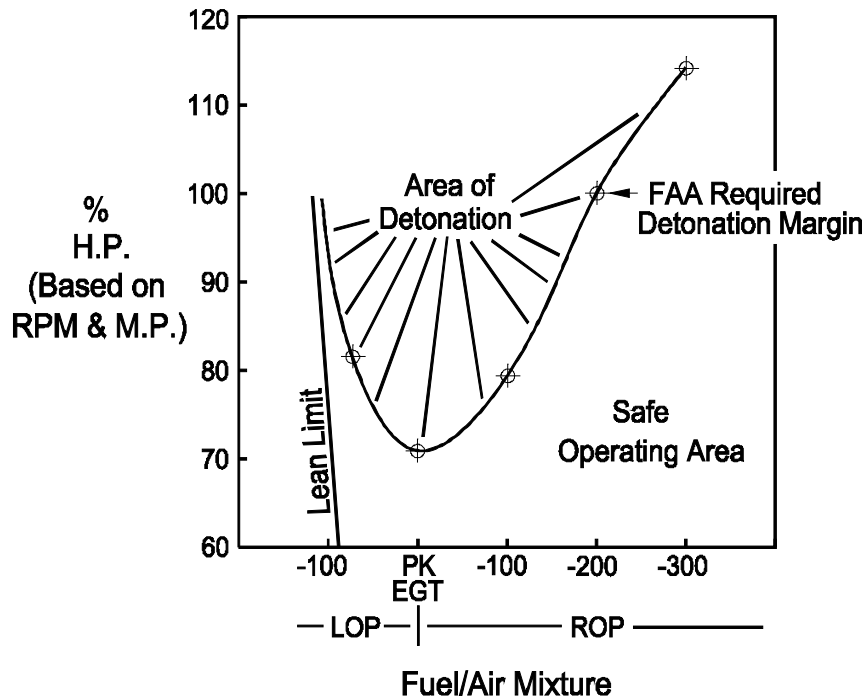

Fig. 13: Operating envelope for an aircraft engine set to the FAA required detonation margin with normal cylinder turbulence.

The exact width of this lean operating window for a given engine is information that is not available. Testing to AC 33.47-1

with detonation detection equipment would be required to determine if a safe lean operating window exists (at high power settings) and what the detonation margin would be for any given engine.

Figure 13 is for an aircraft engine based on research data from test engines. After reviewing this data, Lycoming's recommendation of leaning at 75% power or less and Continental's recommendation of leaning at 65% power or less appear valid. There are aircraft engines damaged by detonation every year, which seems to further support Lycoming's and Continental's recommendations. To avoid detonation we recommend every pilot follow Lycoming's, Continental's or an STC holders power requirements for leaning.

Deposits in the Combustion Chamber: Detonation is caused by the end gas auto-igniting near the surface of hot components in the combustion chamber. An overheated exhaust valve is the most frequent contributor to detonation. Also, as the exhaust gases flow over the exhaust valve, carbon deposits can form on the valve and top of the piston. These deposits take on heat from compression much faster than the cylinder walls and piston. Hot carbon deposits on a hot exhaust valve can be particularly troublesome.

Hot carbon deposits or overheated spark plug electrodes can produce pre-ignition (Ref. Taylor1, 300; Stone, 74, Heywood, 375, Taylor2, 84). Changing the oil frequently and leaning the engine during idle, taxi and cruise will reduce carbon deposits.

CHT: High CHTs will increase surface temperatures in the combustion chamber, including the temperature of the exhaust valve. Also, high CHTs increase the end gas temperature and the chance of detonation.

Inlet Air Temperature: Increased inlet air temperature will increase the temperature of the end gas and can be a significant contributor to detonation in turbocharged aircraft at high altitude. On the other hand, a normally aspirated carbureted engine may benefit from **some** carburetor heat. Fuel evaporation and distribution are very sensitive to inlet temperature. Adding carburetor heat may improve the fuel/air distribution between cylinders and reduce the chance of detonation by richening the leaner cylinders (Ref. Taylor2, 63). It may be helpful to operate with a carburetor temperature that is no more than 10°F above “Standard Day” or 70°F, whichever is less.

Timing: Advancing the timing will increase peak cylinder pressure and the chance of detonation. Detonation is produced by pressurizing *and* heating of the end gas.

RPM: Increasing the engine RPM reduces the burn time, which will slightly reduce the chance of detonation (Ref. Taylor2, 64).

Humidity: Increased humidity has a tendency to reduce detonation.

Fuel: The amount of literature covering the affects of fuel on detonation is enormous. The major development of fuel is targeted around reducing its ability to detonate. The octane rating of fuel is one of the most significant factors that determine an engine’s ability to detour detonation. The higher the octane rating of the fuel, the less chance there is of detonation. Since only 100LL fuel is available in General Aviation, it is not necessary to go into the many properties of fuel that detour detonation.

Compression Ratio: Increasing the compression ratio of an engine is a Design Engineers’ primary method of increasing an engine’s power output for a given engine size. Higher compression ratios increase an engine’s efficiency, horsepower, peak pressure and combustion temperature. Also, high compression ratios significantly increase the chance of detonation.

Leaning Methods

If the airframe, STC holder and/or engine manufacturer’s leaning recommendations for your aircraft engine differ from those presented here, *you must use the airframe and/or engine manufacturer’s recommendations*. It is your responsibility to acquire and use the proper leaning method approved for your engine.

When leaning an aircraft engine the following maintenance and performance issues should be considered:

Detonation (maintenance issue) - Detonation is one of the most destructive operating conditions for an engine. Light (incipient) to moderate (limiting) detonation can lead to heavy detonation which can cause damage over a period of time, with little indication by the engine instruments that a problem exists. A high power setting with too lean a mixture is the major cause of detonation. By leaning to the engine

manufacturer's (or STC holder's) recommended power requirements, there's a good chance of avoiding any excessive heat or pressure damage due to detonation at any mixture setting.

A pilot can inadvertently operate a turbocharged engine at high power settings when flying at high altitudes. At high altitude, backpressure in the exhaust system is reduced, allowing more charge to be packed into the cylinder during the intake stroke. This increases engine power for a given manifold pressure and RPM. Also, running an engine on the boost at high altitudes can significantly increase inlet air temperature. If an engine is leaned with high inlet air temperature and a high power setting, detonation and subsequent engine damage can occur.

Exhaust Valve Temperature (maintenance issue) - High exhaust valve temperature can significantly reduce the life of an exhaust valve. The combination of the EGTs and CHTs affect the temperature of the exhaust valve and its longevity. By keeping the sum of the EGT + CHT below 1825°F for each cylinder, you may extend the life of the exhaust valves.

Cylinder Head Temperature (maintenance issue) - High CHTs can stress an engine, reduce detonation margin and reduce the life of many engine parts. By keeping the CHTs below 400°F for each cylinder, you may reduce the affects of heat.

Carbon Deposits (maintenance issue) - Some carbureted engines (O470, 0520, etc.) have a wide fuel/air distribution between cylinders. The richest cylinders can foul plugs and accumulate an excessive amount of carbon deposits. Some pilots of these engines operate the leanest cylinders LOP in order to keep the richest cylinders from fouling plugs. We have **not** found any roughness in operation when running a carbureted engine's *leanest* cylinders LOP.

Airspeed and Fuel Economy (performance issues) - The leaner operating methods will save fuel but you may see a significant reduction in airspeed. If airspeed is worth the additional cost of fuel, your may want to consider using the "Best Power" leaning method. What is the cost of speed modifications or a bigger engine to gain airspeed verses the cost of fuel to run at best power?

The engine can help dictate a leaning method. Reading the plugs to determine an engine's proper operating temperature and mixture is an old tried and true method still used by many race mechanics. If an engine has cylinders operating with black plugs and carbon build up in cylinder chambers, one of the leaner operating methods should be considered. If an engine has cylinders operating with chalky white or small black and gray spots on the insulator of the spark plugs, a richer operating method should be considered.

Following are a number of leaning methods for the different operations of an aircraft.

Idle and Taxi:

If an engine is consistently operated with black carbon on the plugs, leaning the engine during idle and taxi operation should be considered. Some pilots consistently lean their engines during idle and taxi operation before takeoff and after landing to keep their engine's combustion chambers clean. Some engines run very rich at low RPM and can foul plugs in a short period of time. Leaning an engine at taxi and idle can significantly reduce carbon deposits and plug fouling.

At low power settings, exhaust valve temperatures, CHTs and detonation are not a problem. Therefore, you cannot damage an engine by leaning at idle or taxi. When leaning at low RPM, the mixture control will need to be considerably pulled out before the EGTs start to rise. Remember you can't hurt the engine by leaning, so don't be afraid to be aggressive with the mixture control.

At low RPM, combustion efficiencies (ASE) are low. As you lean your engine it will be difficult to find peak EGT. Once the EGTs make an initial increase they flatten out and do not change much with additional leaning. Any mixture setting after the EGTs reach this flat peak is sufficient to reduce carbon deposits.

An important thing to remember is that during taxi onto the runway for takeoff, **the mixture must be at full rich**. A takeoff with too lean a mixture can cause severe engine damage. Run-up is a good time to insure that the mixture control is set for full rich.

Takeoff and Climb:

The research data clearly indicates that a rich mixture is mandatory to detour detonation. The EGT leaning range for an engine is approximately 300°F from full rich to peak EGT. The change in EGT is fairly linear with a change in the mixture. For most non-turbocharged aircraft engines, EGT readings at takeoff (100% power at sea level) will be 1100°F to 1250°F. Turbocharged engines will run 1200°F to 1350°F. For both turbocharged and non-turbocharged aircraft engines the EGT reading should not go over 1350°F on takeoff.

Takeoffs and Climbs with Lean-of-Peak (LOP) Operation - Unless a detonation survey to AC 33.47-1 has been performed on each cylinder and satisfactory results have been obtained, a full throttle takeoff or climb with LOP operation is not recommended.

High Altitude Takeoffs and Climbs for Non-Turbocharged Engines - As altitude increases air density will decrease causing engine power to decrease and its mixture to become excessively richer. An excessively richer mixture will cause an additional loss of engine power and possibly a rough running engine. To compensate for this loss in power it would be appropriate to lean an engine during climb and for takeoffs at airports with elevations above sea level.

The following changes in the mixture were calculated to correct for an excessively rich mixture during climb. If an engine's CHTs approach their maximum limit, it may be necessary to operate with an excessively rich mixture or reduced power to keep the CHTs in a reasonable operating range.

Lean at Takeoff and Climb for an EGT Reading of:

**Sea Level EGT Reading + 25°F/1000'
(or 1350°F, whichever is less).**

If the full throttle sea level EGT readings are unknown, the approximate values can be derived using the following formula:

$$\text{Sea Level EGT at Full Throttle} = \text{Peak EGT reading at 70\% power} - 300^{\circ}\text{F.}$$

Cruise:

There are many leaning methods available. Below are a number of them for your consideration.

The “Best Power” Leaning Method:

Set the mixture so the *leanest* cylinder operates 100°F rich of peak EGT (see figure 14). This method helps ensure the exhaust valves stay reasonably cool. The engine will produce maximum power for a given throttle setting. Of all the leaning methods presented, this method will produce the highest airspeed, fuel consumption and CHT’s.

For engines that have a wide fuel/air distribution between cylinders (such as carbureted engines and some injected engines), this method may result in some of the cylinders running very rich. These rich cylinders can produce carbon deposits and fouled plugs. If this is the case for your engine, you may want to consider a leaner operating method.

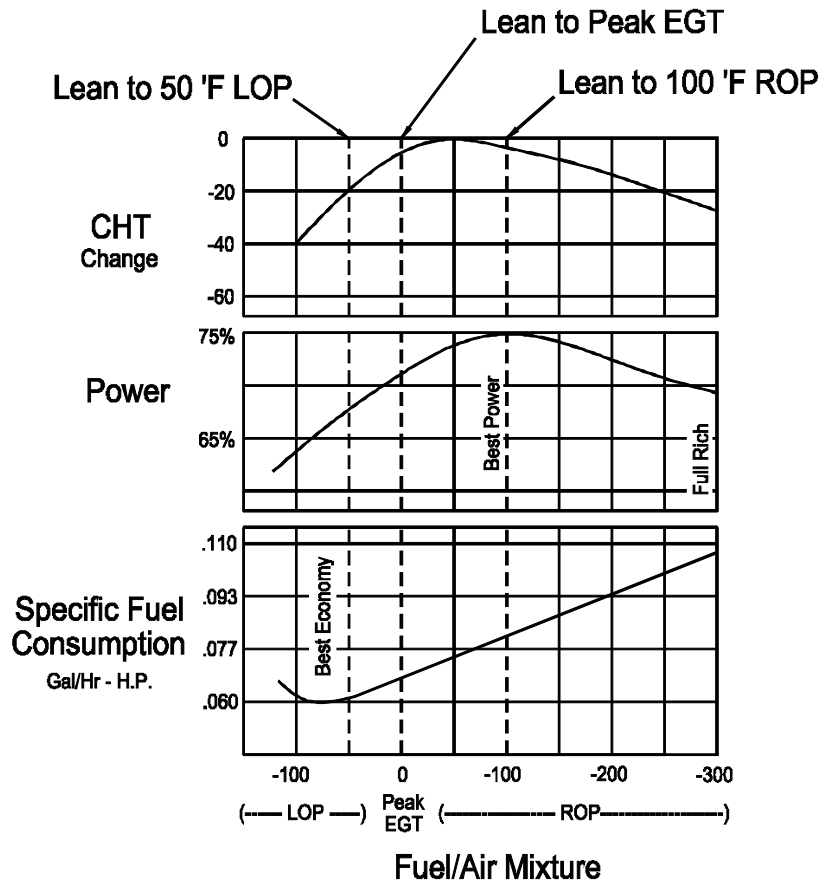

Fig. 14: Shows the CHT, Power and Specific Fuel Consumption versus the EGT reading for a typical aircraft engine.

The “Peak EGT” Leaning Method:

Set the mixture so the *leanest* cylinder operates at peak EGT. At this mixture setting the EGTs will be 100°F hotter than the “Best Power” leaning method” (see figure 14). This method results in the highest temperature on the exhaust valves and heat damage could become an issue. The engine will produce approximately 4% less power and the fuel consumption will be approximately 14% lower than with the “100°F Rich-of-Peak (ROP) Leaning Method.” The CHTs will be near there highest.

The “Lean-of-Peak (LOP)” Leaning Method:

Set the mixture so the *richest* cylinder operates at 30-80°F lean of peak EGT. At this mixture setting the CHTs will be the coolest and the EGT will be 20-70°F hotter than the “100°F Rich-of-Peak (ROP) Leaning Method” (see figure 14). This method results in reasonably cool exhaust valve temperatures. The engine will produce approximately 7+% less power and the fuel consumption will be 20+% lower than with the “Best Power” leaning method.”

The “LOP with Power Recovery” Leaning Method:

This method is **not recommended** unless a detonation survey to AC 33.47-1 has been performed, the result show a safe operating area exists lean of peak for the power levels you plan on using and FAA approval has been obtained.

Set the mixture so the *richest* cylinder operates at 30-80°F lean of peak EGT. Increase the manifold pressure by 1.25" Hg to recover 5% of the power loss (.25" Hg per %H.P.). It is important the richest cylinder is not allowed to drift within 30°F of peak EGT (refer to the detonation survey for your engine). It must remain at LOP operation. E.I.'s UBG-16 has some unique features to help with this process. The lean mixture is required for all cylinders to ensure that detonation does not occur. The higher the power recovery, the higher the chance of detonation.

The fuel consumption and power achieved for an engine by using one of the leaning methods outlined above may vary depending on the fuel/air distribution between cylinders of that engine. For example: A carbureted engine power may not change much as it is leaned past the best power mixture. As the engine is leaned, the leaner cylinders will lose power as the richer cylinders gain power. Also, the specific fuel consumption for some cylinders may be at best economy while the other cylinders will be at best power or richer. Therefore, the specific fuel consumption for the engine will be more than that shown in figure 14.

Descent:

During descent maintain the same leaning method as used during cruise (other than the power recovery method). The manifold pressure will need to be reduced during descent to maintain proper power levels for a lean mixture. When entering a pattern for landing, richen the mixture for a possible full throttle go around.

Shock cooling (cylinder heat temperatures dropping more than 30°F per minute) can be a problem for a few aircraft. Most aircraft *cannot* be shock cooled even during high-speed descents. Although, there are a few aircraft that will shock cool as soon as the nose is lowered. These aircraft seem to have a higher incidence of warped valves and cylinder head cracking problems. To help prevent shock cooling, maintain normal power, a lean mixture and a moderate descent rate.

Matrix of Leaning Methods

Following is a list of advantages (+) and disadvantages (-) of the different leaning methods for the maintenance and performance issues cited.

Maintenance Issues	<i>Leaning Method</i>			
	Best Power	Peak EGT	Lean-of-Peak	LOP w/ Power Recovery (6)
Detonation	++ (1)	+ (1)	++ (1)	- - - (6, 7)
Exhaust Valve Temp.	+	- (4)	+/- (4)	+
Cylinder Head Temp	- (2)	- (2)	+ (5)	+
Carbon Deposits	- (3)	+	++	++
Performance Issues				
Airspeed	+	-	- -	+
Fuel Economy	-	+	++	++

- (1) When leaning to the engine manufacturer's recommended power requirements, the chance of detonation is low.
- (2) If your CHT's are below 400°F, this leaning method is **NOT** a disadvantage.
- (3) If your engine does not have a tendency to develop carbon deposits, this leaning method is **NOT** a disadvantage.
- (4) If your engine has a wide fuel/air distribution between cylinders, some cylinders may be operating near peak EGT. If the EGT + CHT is under 1825°F, this leaning method is **NOT** a disadvantage.
- (5) If your engine has a wide fuel/air distribution between cylinders, some cylinders may be operating near peak CHT. If the CHT is below 400°F, this leaning method is **NOT** a disadvantage.
- (6) This method is **not recommended** unless a detonation survey to AC 33.47-1 has been performed, the result show a safe operating area exists lean of peak for the power levels you plan on using and FAA approval has been obtained. The following data is for an engine with a well balanced fuel/air distribution between cylinders.
- (7) It is important the richest cylinder is not allowed to drift toward peak EGT. It must remain at LOP operation. The lean mixture is required for all cylinders to ensure that detonation does not occur. The higher the power recovery, the higher the chance of detonation.

A Great Engine Analyzer

A great engine analyzer can be the *most effective* tool for avoiding engine problems and adding a significant level of safety to any flight. If an analyzer only displays engine data and requires the pilot to do the majority of the analysis, that pilot may be sadly disappointed in the engine analyzer when an unexpected problem arises. A **great engine analyzer** should automatically find engine problems for the pilot and assist in the **proper** operation of the engine to help avoid engine problems in the first place! Following are some of the features that make an engine analyzer **great**.

Automatically collects and analyzes engine data and displays a warning the second a problem occurs - An engine analyzer that is only “good” comes from the *first* level of technology. It has a bar graph display to show current EGTs and CHTs. Also, it collects engine data and provides a method of downloading the data to a computer for later review of graphs, charts and numbers to detect problems that may be developing. The *second* level of technology in engine diagnostics is to let a computer program pour over the engine data in order to **automatically** find any problems. The *third* level of technology is to provide programmable parameters so the computer program can be customized for each of the engine’s cylinders. This allows for a much more accurate analysis. The *fourth* level of technology is to put the computer in an aircraft and analyze the data in “real” time as it is collected from the engine analyzer. Finding problems early can significantly reduce engine damage. The *fifth* level of technology is to put the entire computer program into the engine analyzer and get rid of the computer.

Only Electronics International’s UBG-16 is a *fifth* level technology engine analyzer, with three on-board microprocessors to *analyze engine data as it is collected*. The UBG-16 analyzes engine data in the same manner as an engineer does: it looks for trends and deviations from normal operating levels. The UBG-16 has 34 pilot-programmable parameters to allow automatic engine analysis to be *customized for each individual cylinder of an engine*. The UBG-16 will automatically detect and alert the pilot of any developing engine problem in *seconds*, rather than the *weeks or even months* it might take to download and analyze data from other bar graph units on the market. For those that like to keep detailed records, the UBG-16 provides an RS-232 output port so data may be collected in E.I.’s MUX-8A Black Box Data Recorder for later review.

A graph is provided to display long-term trends - An engine analyzer which is merely “good” provides a bar graph display of an engine’s EGTs and CHTs. But because the exact height of every column of bars for each cylinder is not easily remembered, it will be difficult to spot trends. A **great engine analyzer** can store offset data for each cylinder in long-term memory. This offset data can be used to display a “normalized” graph of the engine’s current operating temperatures. If all of the engine’s cylinders are healthy, the bar graph will display columns with the same height (see figure 15). If a cylinder develops a problem, that cylinder’s column of bars will be higher or lower than the others. (see figure 16).

It’s easy to enter the UBG-16’s normalized mode any time during a flight. If a cylinder’s EGTs start to drift, that drift can be spotted on the normalized display in seconds. This is the same trend information a pilot would be looking for in down-loaded engine data. *No other engine analyzer has the ability to store offset data in long term memory (100+ years) and use this data to display “real” time trends on its bar graph display.* A major design criterion of the UBG-16 was for it to be able to collect,

process and analyze engine data and alert the pilot of an engine problem as soon as possible, which other bar graph instruments on the market can't do as well or at all!



Fig. 15: Shows Normalized Mode with the engine operating normally.

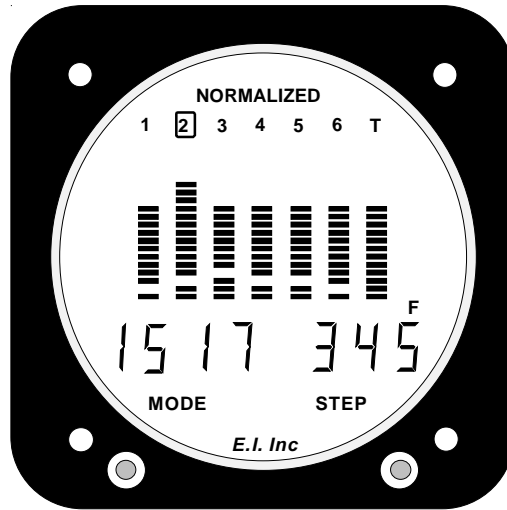

Fig. 16: Shows Normalized Mode with a problem on cylinder #2.

The bar graph display can be scaled to match the operating range of an engine – An engine analyzer which is only “good” keeps the bar height near the middle of the display range for normal engine operation. A **great engine analyzer** (UBG-16) allows you to set the **lower and upper** operating range of the bars to match your engine’s specific operating range. When an engine is running rich, the bars will be low in the display (see figure 17) and when an engine is running lean, the bars will be high in the display (see figure 18). It will be easy to see at a glance how rich or lean the engine is running. This is a big safety feature when taking off, climbing, cruising and descending.



Fig. 17: Shows Normal mode with the engine operating at full rich.



Fig. 18: Shows Normal mode with the engine running lean.

Superior leaning features to assist in rich-of-peak (ROP) and lean-of-peak (LOP) engine operation - An engine analyzer which is only “good” indicates the first cylinder to reach peak EGT during the leaning process. It also indicates how many degrees below peak EGT the leanest cylinder is operating. A **great engine analyzer** (UBG-16) indicates *each* cylinder as it reaches peak EGT. Also, it will indicate how many degrees ROP or LOP *each* cylinder is operating.

Another feature of the UBG-16 is its fuel/air mixture profile mode. In this mode the bar graph display shows how close all of the cylinders are to reaching peak EGT at the same mixture setting.

The UBG-16 was designed to be one of the most valuable tools that can be purchased for an aircraft. The UBG-16 has some advanced features every pilot should consider. These features can provide some real safety and money savings benefits.

Engine Diagnostics

Engine problems can be separated into two categories: “Top End” and “Bottom End.” Bottom-end problems are those associate with the lower half of the engine, e.g., worn bearings, cracks in the crankshaft, connecting rods or case, etc. Problems in the bottom end of an engine are most often caused by sudden engine stoppage or improperly assembled parts. Problems in the bottom end occur infrequently.

Top-end problems are those associated with the upper half of the engine, e.g., stuck valves, burned exhaust valves, worn valve guides, broken valve springs or retainers, cracked valve rockers, defective valve lifters, bent or broken push rods, rusted or worn cam lobes, worn or burned valve seats, cracked cylinders, heat-damaged pistons, broken ring lands, broken or worn rings, out-of-round cylinders, fouled plugs, defective mag wires or mags, plugged injectors, cracks in the injector tubes or flow divider, defective or misadjusted fuel servo, defective fuel pump, leaks in the fuel lines, leaks in the upper deck pressure lines, efficiency problems with the turbo, carburetor problems, plugged return fuel lines, etc, etc, etc.

Top end problems account for the overwhelming majority of problems in an engine. A great engine analyzer can easily spot most top-end engine problems. Without an engine analyzer most of these top-end problems will go undetected. Over time, an undetected problem can cause significant engine damage resulting in an expensive repair bill.

Diagnosing Problems from the EGT Readings:

Understanding the following simple concept and EGT formula can help a great deal in diagnosing engine problems from EGT readings. This concept and EGT formula are taken from differential thermodynamic equations and show the relationship between the energy in the combustion temperature, the energy used to produce horsepower and the exhausted energy.

Concept: Heat = Energy

Think of heat, energy and power as the same thing. Temperature is a measurement of heat energy and horsepower is a measure of energy used. If heat and energy are related, it follows that temperature and horsepower are related.

EGT Formula: $EGT = T_{(Fuel/Air)} - T_{(HP)}$

$T_{(Fuel/Air)}$ = The temperature or energy of combustion produced by the burning of the fuel/air charge. The more charge (measured by fuel flow) delivered to a cylinder, the more potential energy there is available to produce horsepower. During normal operations the temperature of combustion ($T_{(Fuel/Air)}$) is approximately 4000°F.

$T_{(HP)}$ = Temperature or energy used to produce work or horsepower. Also, $T_{(HP)}$ includes the energy used to heat the cylinder heads. As work is done $T_{(HP)}$ draws energy from the temperature of combustion ($T_{(Fuel/Air)}$), reducing it from 4000°F to approximately 1300°F (the **EGT** reading).

EGT = Temperature or energy of the exhaust gases. As the EGT formula shows, the EGTs are the result of fuel/air charge delivered to the engine, less the horsepower the engine produces. If we keep the fuel flow and mixture the same, anything that reduces engine horsepower will result in higher EGTs.

This simple EGT formula can be used to diagnose any top-end problem. All problems will fall under one of the following four categories.

Mixture - The following examples show how the EGT Formula applies to the different areas of leaning:

1. Leaning from Full Rich to Best Power (100°F rich of peak EGT):

$$\uparrow EGT = \uparrow T_{(Fuel/Air)} - \uparrow T_{(HP)}$$

As the engine is leaned from full rich to best power (100°F rich of peak EGT), $T_{(Fuel/Air)}$ and $T_{(HP)}$ will increase due to additional heat energy released in the fuel. Since the engine is not 100% efficient, $T_{(Fuel/Air)}$ will increase more than $T_{(HP)}$, resulting in an increase in **EGT**. The EGT will increase approximately 200°F from full rich to best power mixture.

2. Leaning from Best Power to Peak EGT:

$$\uparrow EGT = T_{(Fuel/Air)} - \downarrow T_{(HP)}$$

As the engine is leaned from Best Power to Peak EGT $T_{(Fuel/Air)}$ will stay about the same, $T_{(HP)}$ will decrease due to the slow burn of the fuel air mixture and the reduction of the peak cylinder pressure and as a result the **EGT** will increase approximately 100°F.

3. Leaning from Peak EGT to Lean Misfire:

$$\downarrow \text{EGT} = \downarrow T_{(\text{Fuel/Air})} - \downarrow T_{(\text{HP})}$$

As the engine is leaned from Peak EGT to Lean Misfire $T_{(\text{Fuel/Air})}$ and $T_{(\text{HP})}$ will decrease due to less energy in the fuel. As a result the **EGT** will decrease approximately 100°F at which point the engine will start to misfire.

Some engine problems that fall under the “Mixture” category are:

- Plugged injectors.
- Worn or defective injectors.
- Leaks in the fuel lines and flow divider.
- Misadjusted or defective fuel controller.
- Misadjusted or defective carburetor.
- Fuel distribution problems.
- Intake leak.
- Defective fuel pump.
- Leaks in upper deck lines.
- Intake or exhaust restriction.

Compression - The higher the compression ratio of an engine the more horsepower ($T_{(\text{HP})}$) it will produce for a given amount of fuel/air charge. Anything that reduces the effective compression ratio (such as leaks around the valves or rings) will reduce horsepower ($T_{(\text{HP})}$) and increase the **EGT** ($\uparrow \text{EGT} = T_{(\text{Fuel/Air})} - \downarrow T_{(\text{HP})}$). A leak in an exhaust valve can result in a 20-200°F rise in that cylinder’s EGT.

Some engine problems that fall under the “Compression” category are:

- Burned valve.
- Broken or worn ring.
- Worn or burned valve seats.
- Out-of-round cylinder.
- Rings that will not seat.
- Defects in the rocker arm, push rod, valve lifter, valve spring or any other component that holds the exhaust or intake valve open during the combustion stroke.

Timing - As the spark timing is retarded from optimum, peak pressure of combustion occurs later than normal, which reduces horsepower ($T_{(\text{HP})}$). As the EGT formula shows ($\uparrow \text{EGT} = T_{(\text{Fuel/Air})} - \downarrow T_{(\text{HP})}$), the **EGTs** will increase. Some engine problems such as a fouled plug can also produce a retarded timing for a single cylinder. Any problem that causes one of the plugs to misfire increases the time required to burn the fuel/air charge in a cylinder, which effectively retards the timing.

If the spark timing is advanced from optimum, peak pressure of combustion will increase and occur earlier than normal. This causes the combustion energy to increase ($T_{(\text{Fuel/Air})}$), horsepower to drop

slightly and the heat transfer to the cylinder heads to increase ($T_{(HP)}$). The net result is little change in the EGT readings.

Some engine problems that fall under the “Timing” category are:

- Fouled plugs.
- Defective mag wires.
- Mag failure.
- Misadjusted spark time on one or both mags.
- Detonation. Detonation advances the timing due to the last portion of the charge being burned all at once.
- Lean mixture. Although not a problem, a lean mixture does take longer to burn.

Charge - Increasing the throttle increases fuel/air charge delivered to the engine ($T_{(Fuel/Air)}$) and increases engine horsepower ($T_{(HP)}$). E.I.’s fuel flow instrument provides a good measurement of the energy delivered to the engine. Since the engine is not 100% efficient, $T_{(Fuel/Air)}$ will increase more than $T_{(HP)}$ resulting in the EGT increasing approximately 1 to 1.5 °F per horsepower (assuming the mixture stays the same) ($\uparrow EGT = \uparrow T_{(Fuel/Air)} - \uparrow T_{(HP)}$).

Some engine problems that fall under the “Charge” category are:

- RPM gauge reads low (commonly seen in analog gauges).
- Manifold pressure gauge reads low.
- Efficiency problems with the turbo.
- Worn cam lobes.
- Intake or exhaust restriction.

At the back of this manual is an “Engine Diagnostic Reference Guide.” This guide describes a number of engine problems and their associated symptoms.

Diagnosing Problems from the CHT Readings:

The following CHT formula will help in diagnosing problems using the CHT readings.

CHT Formula: $CHT = T_{(HP)} - T_{(Cooling)}$

$T_{(HP)}$ = Temperature or energy to produce horsepower.

$T_{(Cooling)}$ = Temperature or energy used to cool the cylinder head.

CHT = Temperature of the cylinder head.

When it comes to diagnosing most engine problems that have a major affect on the EGTs, the CHT readings are a good backup but used alone they are not a good troubleshooting aid. Because the amount of cooling energy ($T_{(Cooling)}$) available is affected by airspeed, OAT, cowl flap setting, altitude, humidity, barometric pressure and adjacent cylinder head temperatures, the CHT readings from flight to flight can vary significantly. Also, if a

cylinder develops a problem and produces less power ($T_{(HP)}$ reduces), then the airspeed may also reduce. This reduction in airspeed reduces $T_{(Cooling)}$ causing a small net change in the CHT reading, which may go unnoticed.

CHT readings easily can display problems related to engine cooling, while EGT readings will not show these problems at all. Some engine problems that fall under the “Cooling” category are:

- Deterioration of the baffle seals.
- Broken stiffening tabs.
- Problems with the inner cylinder baffles.
- Defective or misadjusted cowl flap linkage.
- Air restriction under the cowl (shop rag, shop tools, bird nest, rat nest, etc.)

Some engine problems that fall under the “Horsepower” category are:

- High horsepower settings.
- Detonation.
- Pre-ignition.

At the back of this manual is an “Engine Diagnostic Reference Guide.” This guide describes a number of engine problems and their associated symptoms.

Engine Tests:

At the back of this manual are some tests that can be very helpful in diagnosing engine problems. Following is a list of those tests:

Base Line Comparison Test - Every engine and every cylinder has its own unique operating temperatures. If you have recorded the normal operating temperature for each cylinder of your engine for a specific flight condition at an earlier date, you can compare current temperatures with your base line temperatures to help spot engine problems. Establishing a base line is the single most important thing you can do toward diagnosing engine problems from trend data. The UBG-16’s long term normalized mode can establish a base line automatically.

Lean Range Test - This test checks the EGT range from full rich to peak EGT. A 200-300°F range is normal. If a cylinder is running with an EGT reading higher than normal, this test will tell you if the problem is due to a leaner than normal mixture. A partially plugged injector or an intake leak could cause a leaner than normal mixture on a single cylinder.

Mag Test - This test checks the EGT reading when operating on the left mag and when operating on the right mag. A large difference in the EGT reading between the left and right mag operation could indicate a mag timing or spark problem.

Intake Leak Test - This test checks for an intake leak. An intake leak can cause a cylinder to run lean at lower throttle settings. At high throttle settings an intake leak will have little effect on the mixture due to

the low pressure difference between high atmospheric pressure and the high manifold pressure. At low throttle settings an intake leak can cause a cylinder or bank of cylinders to run lean due to the combination of high atmospheric pressure and low manifold pressure causing additional air to be injected through the leak into the intake system.

Leak Down Compression Test - This test checks a cylinder for a leak around the exhaust valve, intake valve or piston ring. A Leak Down Compression Test is performed at every annual and is **not** listed at the back of this manual.

Fuel Flow / Horsepower Test - This test calculates the horsepower from fuel flow. If the mixture is set full rich, an engine should produce .1 to .11 Gal/HP. If the fuel flow and mixture is correct but the engine is not making horsepower, the EGTs will read high ($\uparrow \text{EGT} = T_{(\text{Fuel/Air})} - \downarrow T_{(\text{HP})}$). This test can help spot some engine problems that could otherwise be very difficult to find.

Engine Problems:

Over the last 24 years E.I. has helped thousands of customer troubleshoot engine problems. Following is a list of some of the more interesting engine problems experienced by E.I. customers, as well as the troubleshooting methods used to find the problems. Not all customers use the best troubleshooting method but they are useful to learn from.

Problem #1: $\uparrow \text{EGT} = \uparrow T_{(\text{Fuel/Air})} - \uparrow T_{(\text{HP})}$
Problem Categories: Mixture, Compression, Timing and Charge.

Symptom:

The #3 EGT reading on the customer's UBG-16 was approximately 150°F hotter than the other cylinders at cruise power. The UBG-16 was displaying a differential EGT warning. The aircraft engine was running fine.

Diagnostics:

1. The "Lean Range Test" was performed. The results showed that cylinder # 3 was running too lean. *This is a "Mixture" problem. Takeoffs with a lean cylinder can destroy an engine.*
2. The #3 injector was checked for an obstruction. Nothing was found.
3. The "Intake Leak Test" was performed. Nothing was found. Pressure was put on the pilot by his mechanic to fly the airplane because the mechanic believed there was probably nothing wrong with the engine. E.I.'s position was "*Do Not fly this aircraft with power settings above 75%. A lean running cylinder during take off can detonate and destroy the engine.*"
4. On removing the injector for the third time a split on the underneath side of the hard fuel line from the spider to the injector was found. Fuel was spraying on the engine during normal operation. When the aircraft was on the ground and the cowl was open, the fuel had evaporated leaving no sign of a problem.

Problem # 2: $\uparrow \text{EGT} = \uparrow T_{(\text{Fuel/Air})} - \uparrow T_{(\text{HP})}$
Problem Categories: Mixture, Compression, Timing and Charge.

Symptom:

Cylinder #1 required a top overhaul every 12 months for a burned exhaust valve. The pilot was properly leaning the engine to the TIT (100°F rich of peak TIT). The CHTs were operating around 400°F.

Diagnostics:

1. A UBG-16 was installed in the aircraft.
2. The pilot found the typical EGT spread between the cylinders to be the problem. Since the TIT is an average of all the EGTs (plus an increase in temperature for compression at the inlet of the turbo), some of the cylinders were operating richer and some were operating leaner than 100°F rich of peak **EGT**. When the mixture was set 100°F on the rich side of peak **TIT**, Cylinder #1 was operating at 1650°F (**peak EGT**). At this temperature the exhaust valve life for cylinder #1 was being exceeded every 12 months. *This was a “Mixture” problem.*

Problem # 3: $\uparrow \text{CHT} = T_{(\text{HP})} - \downarrow T_{(\text{Cooling})}$
Problem Categories: Cooling and Horsepower.

Symptom:

An overhauled engine was installed in the aircraft. Cylinder #5 indicated a CHT reading 75°F higher than the next highest CHT.

Diagnostics:

1. The EGTs appeared normal.
2. The Lean Range Test showed no “Mixture” problem. *E.I. suspected a Cooling” problem.*
3. After a detailed inspection of the baffle seals a four-inch tab over cylinder #5 was found to be bent up. In its proper position, the tab diverted the incoming air down through the inner cylinder baffles of cylinder #5. The tab was bent back down and the CHT readings for cylinder #5 dropped down to the level of the other cylinders. The US-8A no longer displayed a CHT differential warning.

Problem # 4: $\uparrow \text{EGT} = T_{(\text{Fuel/Air})} - \downarrow T_{(\text{HP})}$
Problem Categories: Mixture, Compression, Timing and Charge.

Symptom:

The UBG-16 was displaying an intermittent warning for cylinder #3. The EGT reading for cylinder #3 read high intermittently.

Diagnostics:

1. The Lean Range Test indicated the peak EGT for cylinder # 3 was 1510°F. Cylinder #3's EGT jumped above 1510°F (up to 1580°F+) when the problem occurred. *The problem could not be a "Mixture" problem. A "Compression" problem was suspected.*
2. The Leak Down Compression Test indicated no problem. *A sticky exhaust valve was suspected. A sticky intake valve would cause audible backfiring, as E.I. has seen before.*
3. Inspection of the exhaust valve and components found no problems. The intermittent high EGT readings for cylinder # 3 persisted.
4. All of the exhaust valve components were replaced. The problem was fixed. Further inspection of the components showed the exhaust valve lifter was misassembled, causing oil to be trapped in the lifter. This trapped oil would not allow the lifter to compress properly and would hold the exhaust valve slightly open, causing the intermittent high EGT readings.

Problem # 5: $EGT = \downarrow T_{(Fuel/Air)} - \downarrow T_{(HP)}$

Problem Categories: Mixture, Compression, Timing and Charge.

Symptom:

A zero time engine was installed in the aircraft. The climb rate seemed lower than normal and cruise airspeed seemed a little slow.

Diagnostics:

1. The EGTs were in a normal operating range for climb and cruise. The Lean Range Test showed the mixture for all cylinders was running too rich but the engine could still be leaned properly.
2. With the mixture leaned properly the engine still seemed to be low on power.
3. Engine timing was checked and a Mag Test was performed. *Timing was not the problem.*
4. A Leak Down Compression Test was performed. No problem was found.
5. In cruise, with the engine leaned to 250°F rich of peak EGT, the fuel flow at 75% power was **16.3 gal/hr**. The fuel flow should have been (260 HP x .75 x .1 gal/HP) **19.5 gal/hr**. *This was a "Charge" (low power) problem with all cylinders.*
6. The intake and exhaust system were inspected for restrictions. No problem was found.
7. The exhaust and intake valve and components were inspected. No problem was found.
8. A wrong cam or cam timing problem was suspected. This would cause the engine to intake less fuel/air charge and produce less power. This would be the same as flying with reduced throttle, with the manifold pressure indicating normal.

9. The engine was removed from the aircraft and returned to the builder.

10. Twenty days later the engine was returned to the customer. A defective cam was sited as the problem.

11. The engine was reinstalled in the aircraft. The engine produced 100% power and operated normally.

Problem # 6: $\uparrow \text{EGT} = \uparrow T_{(\text{Fuel/Air})} - \uparrow T_{(\text{HP})}$

Problem Categories: Mixture, Compression, Timing and Charge.

Symptom:

A new engine and a UBG-16 were installed in the aircraft. The pilot took off and climbed out over the ocean (as required). On the climb out the pilot did not notice the very high EGT readings. *The engine was running lean and the leanest cylinders were detonating.* At 3,000 ft a cylinder exceeded the EGT limit on the UBG-16 and the red warning light came on. *One of the leanest cylinders was pre-igniting.* At this point the pilot turned the aircraft back towards the airport and continued a full throttle climb. Thirty seconds later the engine started violently shaking the aircraft. *A hole was burned through the top of one of the cylinders.* The pilot reduced throttle and called an emergency. The pilot was cleared for a direct approach to the departing airport. The pilot was capable of safely flying the aircraft at reduced power. Two miles from the airport, over water, the engine seized. *All of the engine oil was blown out of the top of the piston.* The pilot glided the aircraft the last two miles and made a safe landing.

Diagnostics:

Three of the cylinders had partially plugged injectors with rubber particles from the new fuel hoses.

Warning

Engine diagnostic information is intended to assist in finding engine problems only. It is not to be used to identify a problem and then alter the operation of the aircraft or engine. Consult your POH and contact your aircraft manufacture, engine manufacture, local FAA, flight instructor or any other approved organization for inflight interpretation of engine problems and for proper engine and aircraft operation for a particular problem.



Engine Diagnostic Reference Guide



Page 1 of 2

$EGT = T_{(Fuel/Air)} - T_{(HP)}$ (Problem Categories: **Mixture, Compression, Timing** and **Charge**)

$CHT = T_{(HP)} - T_{(Cooling)}$ (Problem Categories: **Cooling** and **Horsepower**)

p = primary measurement

Problem	Problem Category	EGT	CHT	Tests Performed and Results
Partially Plugged Injector.	$T_{(Fuel/Air)}$ ↑ Mixture	p ↑ (1 Cyl)	↑	Failed "Lean Range Test." Failed "Base Line Comparison Test"
	Note: If the cylinder is leaned past peak EGT, the EGT and CHT readings may drop back down to near normal.			
Burned Exhaust Valve. Defective Exhaust Valve Components. Broken or Worn Ring. Ring not seated. Out of Round Cylinder.	$T_{(HP)}$ ↓ Compression	p ↑ (1 Cyl)	* ↓	Failed "Base Line Comparison Test" Failed "Leak Down Compression Test."
	* CHT readings may be only slightly lower than normal.			
Fouled Plug. Defective Mag Wires. Defective Mag.	$T_{(HP)}$ ↓ Timing	p ↑ (1 Cyl)	* ↓	Failed "Mag Test" Failed "Base Line Comparison Test"
	* CHT readings may be only slightly lower than normal.			
Sticky Exhaust Valve	$T_{(HP)}$ ↓ Compression	p ↑ (1 Cyl)	No Change	
	The EGT reading may jump intermittently jump to a high level.			
Sticky intake Valve	$T_{(Fuel/Air)}$ ↓ Charge	p ↓ (1 Cyl)	No Change	
	The engine may make a loud popping sound as the charge in the intake manifold is ignited.			
Leak in the Fuel Lines. Leak in the Flow Divider. Defective Fuel Pump. Restriction in the Fuel Line. Misadjusted Fuel Servo or Carburetor.	$T_{(Fuel/Air)}$ ↑ Mixture	p ↑ (All Cyls)	↑	Failed "Lean Range Test." Failed "Base Line Comparison Test"
	Note: If the cylinders are leaned past peak EGT, the EGT and CHT readings for each cylinder will drop back down to near normal.			



Engine Diagnostic Reference Guide



EGT = $T_{(Fuel/Air)} - T_{(HP)}$ (Problem Categories: **Mixture, Compression, Timing and Charge**)

CHT = $T_{(HP)} - T_{(Cooling)}$ (Problem Categories: **Cooling and Horsepower**)

p = primary measurement

Problem	Problem Category	EGT	CHT	Tests Performed and Results
Retarded Spark Timing on One Mag.	$T_{(HP)} \downarrow$ Timing	p \uparrow (All Cyls)	* \downarrow	Failed "Mag Test" Failed "Base Line Comparison Test"
	* CHT readings may be only slightly lower than normal.			
Intake Leak	$T_{(Fuel/Air)} \uparrow$ Mixture	p \uparrow (1 Cyl) or Bank of Cyls	\uparrow	Failed "Lean Range Test." Failed "Intake Leak Test." Failed "Base Line Comparison Test"
	Note: If the cylinder is leaned past peak EGT, the EGT and CHT readings may drop back down to near normal.			
Detonation	$T_{(Fuel/Air)} \uparrow$ $T_{(HP)}$ Timing	\downarrow (1 Cyl)	\uparrow	
	This problem is difficult to spot even when heat damage is occurring in the combustion chamber. Damage is usually confined to a small area.			
Beginning Pre-ignition	$T_{(Fuel/Air)} \uparrow$ Timing	p \downarrow (1 Cyl)	p \uparrow	You may only have seconds to spot this problem before it moves to damaging pre-ignition.
Damaging Pre-ignition	$T_{(Fuel/Air)} \uparrow$ Timing	p \uparrow (1 Cyl)	p \uparrow	A single stroke of pre-ignition may destroy the engine.
Deterioration of the baffle seals. Defective Inner Cylinder Baffles. Defective Cowl Flap Linkage. Air Restriction Under the Cowl.	$T_{(cooling)} \downarrow$ Cooling	No Change	p \uparrow (All Cyls)	Failed "Base Line Comparison Test"
	Since these problems do not affect $T_{(Fuel/Air)}$ or $T_{(HP)}$, the EGT readings may not be affected.			
Worn Cam Lobe (Carbureted Engine)	$T_{(Fuel/Air)} \downarrow$ Charge	\downarrow	\downarrow	Failed "Base Line Comparison Test" Failed "Fuel Flow / H.P. Test"
	Small changes in horsepower will be difficult to detect. On a fuel-injected engine a worn cam lobe may cause the cylinder to run rich (low EGT readings).			
				Electronics International Inc. ®

Base Line Comparison Test

Page 1 of 2

Aircraft N#: _____ Engine: _____ Date: _____
 Aircraft Type: _____ Engine H.P.: _____ Tach Time: _____

Purpose: Every engine and every cylinder has its own unique operating temperatures. If you have recorded the normal operating temperature for each cylinder of your engine for a specific flight condition at an earlier date, you can compare *current* temperatures with *base line* temperatures to spot engine problems. Establishing a base line is the single most important thing you can do toward diagnosing engine problems.

Rule-of-Thumb: If you have not established a base line, you can compare the data collected on your engine with the following “Rule-of-Thumb” parameters.

- * Most engines idle with an EGT reading around 900 to 1000 °F.
- * Most engines operate at full throttle and full rich around 1200 °F (+/- 100 °F).
- * Most engines have a peak EGT at cruise around 1500 °F (+/- 50 °F).
- * Most turbocharged engines have a peak EGT at high altitude 75% power cruise around 1600 °F.
- * Most fuel injected engines have an EGT spread between hottest and coldest cylinders around 80°F except as follows: IO520 and IO470 have EGT spreads around 110 °F.
- * Most carbureted engines have an EGT spread between hottest and coldest cylinders around 150°F except as follows: O520 and O470 have EGT spreads around 200 °F or more.
- * Most engines have a CHT spread between hottest and coldest cylinders around 65 °F.

1st Test: Record the engine parameters at full throttle, full rich and level flight.

Setup	Date	OAT	Alt.	RPM	MP	Fuel Flow	H.P. from Chart
Current							
Base Line							
Test	Cylinder #1 EGT	Cylinder #2 EGT	Cylinder #3 EGT	Cylinder #4 EGT	Cylinder #5 EGT	Cylinder #6 EGT	
Current							
Base Line							
Differnece (Current - Base Line)							



Electronics International Inc. ®

Base Line Comparison Test

Page 2 of 2

2nd Test: Record the engine parameters at cruise power, level flight and with the leanest cylinder leaned to peak EGT.

Setup	Date	OAT	Alt.	RPM	MP	Fuel Flow	H.P. from Chart
Current							
Base Line							
EGT Tests	Cylinder #1 EGT	Cylinder #2 EGT	Cylinder #3 EGT	Cylinder #4 EGT	Cylinder #5 EGT	Cylinder #6 EGT	
Current							
Base Line							
Difference (Current - Base Line)							
CHT Tests	Cylinder #1 CHT	Cylinder #2 CHT	Cylinder #3 CHT	Cylinder #4 CHT	Cylinder #5 CHT	Cylinder #6 CHT	
Current							
Base Line							
Difference (Current - Base Line)							

Diagnostic Information: In addition to the above tests we recommend you perform the “Lean Range Test,” “Mag Test,” and the “Fuel Flow / Horsepower Test” and keep these tests as additional base line information. When comparing “Current” readings to the “Base Line” readings look for any differences. If all the “Current” cylinder temperatures are higher or lower than the “Base Line” temperatures, this may be due to the differences in the engine operating parameters between the tests. If a single cylinder is higher or lower than the “Base Line,” you may have a problem. See the “Engine Diagnostic Reference Guide” for more information.



Electronics International Inc. ®

Lean Range Test

Aircraft N#: _____ Engine: _____ Date: _____
 Aircraft Type: _____ Engine H.P.: _____ Tach Time: _____

Purpose: This test checks the EGT leaning range of each cylinder from full rich to peak EGT. If a cylinder is running with an EGT reading hotter than normal, this test can help in determining if the problem is due to a leaner than normal mixture.

Test Setup: Cruise, Level Flight, 65% to 75% Power, Full Rich.

Altitude: _____ RPM: _____ H.P. from Chart: _____
 OAT: _____ M.P.: _____

Test: As you lean the engine from full rich to peak EGT, record the EGT readings as each cylinder reaches peak EGT.

Mixture	Fuel Flow	Cylinder #1 EGT	Cylinder #2 EGT	Cylinder #3 EGT	Cylinder #4 EGT	Cylinder #5 EGT	Cylinder #6 EGT
Full Rich:							
1st Cyl to Reach Peak: (Leanest Cylinder)							
2nd Cyl to Reach Peak:							
3rd Cyl to Reach Peak:							
4th Cyl to Reach Peak:							
5th Cyl to Reach Peak:							
6th Cyl to Reach Peak: (Richest Cylinder)							
Lean Range (Peak - Full Rich):	-----						

Diagnostic Information: A "Lean Range" of 250-300 °F is normal. Some carburetors will automatically lean the engine when the throttle is less than full. If this is the case with your engine, the leaning range will be less than 250 °F (usually around 100 to 200 °F). If a cylinder has a significantly less leaning range than the other cylinders, it may have a problem. A partially plugged injector, leak in the tube from the flow divider to the injector or an intake leak could cause a leaner than normal mixture on a single cylinder. If the leaning range for all the cylinders is low, you could have a defective fuel pump, fuel leak, mis-adjusted fuel servo or carburetor.

Mag Test

Aircraft N#: _____ Engine: _____ Date: _____
Aircraft Type: _____ Engine H.P.: _____ Tach Time: _____

Purpose: This test checks the EGT readings when operating on the left mag and on the right mag. A large difference in the EGT reading between the left and right mag operation may indicate a mag timing or spark problem.

Test Setup: Runup, 1750 RPM, Full Rich.

RPM: _____

M.P.: _____

Test: Record the EGT readings for each cylinder when operating on both mags, the left mag and then the right mag.

Mag	Cylinder #1 EGT	Cylinder #2 EGT	Cylinder #3 EGT	Cylinder #4 EGT	Cylinder #5 EGT	Cylinder #6 EGT
Both						
Left						
Right						
Difference (Left - Right)						

Diagnostic Information: When operating on the left or right mag the EGT reading for each cylinder should rise approximately 50 to 100 °F. If any cylinder's EGT drops, that cylinder may have a fouled plug, defective mag wire, or faulty mag.

Normally the maximum "Difference" between the EGT readings when operating on the left mag and right mag is around 25 °F. If the "Difference" is significantly more than this for a set of EGT readings on one mag, you may have a timing problem with one of the mags. The higher the EGT readings on one mag, the more retarded the timing may be on that mag.



Electronics International Inc. ®

Intake Leak Test

Aircraft N#: _____ Engine: _____ Date: _____
Aircraft Type: _____ Engine H.P.: _____ Tach Time: _____

Purpose: This test was designed to check for an intake leak. The suspected problem cylinder (or bank of cylinders) would have failed the “Lean Range Test.” An intake leak may cause a single cylinder (or a bank of cylinders) to run lean at low throttle settings. At low throttle settings there is a significant difference between the high atmospheric pressure and the low manifold pressure. This pressure difference will cause air to leak into the intake manifold causing the affected cylinder to run lean. At high throttle settings an intake leak will have little effect on the mixture due to the low pressure difference between the high atmospheric pressure and the high intake manifold pressure.

Test: Record the EGT readings for each cylinder at full throttle, full rich, level flight and then again at 55% power, full rich, level flight.

Test	Cylinder #1 EGT	Cylinder #2 EGT	Cylinder #3 EGT	Cylinder #4 EGT	Cylinder #5 EGT	Cylinder #6 EGT
Full Throttle						
55% Power						
Difference (Full - 55%)						

Diagnostic Information: The “Difference (Full - 55%)” should be similar between all cylinders. If there is a large “Difference” in one cylinder, you may have an intake leak. The cylinder with the intake leak may fail the “Lean Range Test” and may run hotter than normal at 55% power. At full throttle this cylinder may operate with nearly normal EGT readings.



Electronics International Inc. ®

Fuel Flow / Horsepower Test

Aircraft N#: _____ Engine: _____ Date: _____
 Aircraft Type: _____ Engine H.P.: _____ Tach Time: _____

Purpose: This test calculates the horsepower from fuel flow. If the mixture is set correctly, an engine should produce .1 to .11 Gal/HP.

Test Setup: Level Flight, Full Throttle, Full Rich.

Altitude: _____ RPM: _____
 OAT: _____ M.P.: _____

Test: Record the fuel flow and EGT readings for each cylinder at full throttle, full rich and level flight.

Test	Cylinder #1 EGT	Cylinder #2 EGT	Cylinder #3 EGT	Cylinder #4 EGT	Cylinder #5 EGT	Cylinder #6 EGT
Full Throttle						

Fuel Flow: _____ Calculated H.P. (Fuel Flow / .1) = _____
 H.P. from Engine Chart ----- = _____

Diagnostic Information: If the “Calculated H.P.” is significantly lower than the “H.P. from Engine Chart,” you could have a worn intake or exhaust cam lobe. An intake or exhaust cam lobe would have to be significantly worn to affect engine horsepower. **A worn cam lobe is not a common problem.** On a fuel injected engine a worn cam lobe may show up as a rich running cylinder with low EGT readings. On a carbureted engine a worn cam lobe may show up with normal EGT readings.



Electronics International Inc. ®

References

Avco Lycoming, Avco Lycoming certificated Aircraft Engines
SSP 283,

Heywood, J. B. Professor of Mechanical Engineering Director, (1988).
Internal Combustion Engine Fundamentals, MIT, McGraw-Hill inc.

Lumley, J. L. Sibley School of Mechanical and Aerospace Engineering, Cornell University (2000).
Engines an Introduction, Cambridge University Press.

Stone, Richard, Department of Engineering Science, University of Oxford, (1999).
Introduction to Internal Combustion Engines, Third Edition, SAE.

Taylor, C. F. Professor of Automotive Engineering, MIT, (1985)
The Internal-Combustion Engine in Theory and Practice, **Volume 1**, The MIT Press, Cambridge
Massachusetts and London, England.

Taylor, C. F. Professor of Automotive Engineering, MIT, (1985)
The Internal-Combustion Engine in Theory and Practice, **Volume 2**, The MIT Press, Cambridge
Massachusetts and London, England.